



# ***VO40 Open-Center Directional Control Valve***

*Catalog HY14-2720/US*



 **WARNING**

FAILURE OR IMPROPER SELECTION OR IMPROPER USE OF THE PRODUCTS AND/OR SYSTEMS DESCRIBED HEREIN OR RELATED ITEMS CAN CAUSE DEATH, PERSONAL INJURY AND PROPERTY DAMAGE.

This document and other information from Parker Hannifin Corporation, its subsidiaries and authorized distributors provide product and/or system options for further investigation by users having technical expertise. It is important that you analyze all aspects of your application and review the information concerning the product or system in the current product catalog. Due to the variety of operating conditions and applications for these products or systems, the user, through its own analysis and testing, is solely responsible for making the final selection of the products and systems and assuring that all performance, safety and warning requirements of the application are met.

The products described herein, including without limitation, product features, specifications, designs, availability and pricing, are subject to change by Parker Hannifin Corporation and its subsidiaries at any time without notice.

**Offer of Sale**

The items described in this document are hereby offered for sale by Parker Hannifin Corporation, its subsidiaries or its authorized distributors. This offer and its acceptance are governed by the provisions stated in the "Offer of Sale".

© Copyright 2006 Parker Hannifin Corporation, All Rights Reserved

<b>Introduction</b> .....	1
<b>Technical Information</b>	
General Description.....	3
Operation.....	3
Benefits .....	3
Specifications .....	4
Weights.....	4
Connections .....	4
Performance Curves.....	5
Environmental Characteristics.....	5
Schematic Circuit Types .....	6
Dimensions.....	7-8
Handle Actuation vs. Spool Direction .....	9
<b>Ordering Information</b>	
How to Order .....	10
General Valve Assembly.....	11
Inlet Cover .....	12-13
Outlet Cover .....	14-15
Work Sections .....	16-20
Mid-Inlet.....	21
<b>Assembly Configuration Form</b> .....	22
<b>Offer of Sale</b> .....	23

### **Breadth of Line**

Parker Hannifin is a Fortune 300 company with sales of \$8 billion and over 400,000 customers in 46 countries. Parker is the world's leading supplier of motion control components and system solutions, serving the mobile, industrial and aerospace markets.

Parker is your single source for any hydraulic valve requirement. We provide a wide selection of open-center and load-sense directional control valves for any construction, off-highway, or on-highway application. Many of our open-center valves can be adapted and used as closed-center, constant-pressure, and constant-pressure unloaded valves. Each of these technologies offers unique features for improved



machine performance over traditional, open-center control valves.

When remote control is required, Parker provides a broad line of pilot controllers that are compact and pressure-matched with our control valves to provide consistent and optimized machine control. There are a variety of electric-switch handle options available for additional function control by the operator.

Parker's premier IQAN electronics packages range from simple stand-alone controllers to large, multiple CAN bus systems with color displays. For example, IQAN interfaces with new electronic diesel engines over the SAE J1939 CAN bus.

Package components are designed and

tested for mobile applications to help increase machine uptime. The IQAN valve drivers offer superior control of proportional hydraulic functions resulting in increased machine productivity. Non-programmers find IQAN's programming interface easy to use, reducing development time. Furthermore, excellent diagnostic tools and remote modem connection help cut field service time.

### **Total Machine Motion Control**

You can turn to us for all your mobile motion control solutions. We offer stand-alone valves, as well as custom-designed manifolds with integrated directional control valves.

No matter what type of system you choose, Parker solutions provide top-notch performance and reliability. Our systems are optimized to reduce complexity, size, cost, and fluid leakage. Therefore, working with Parker can significantly cut your machine-build time.

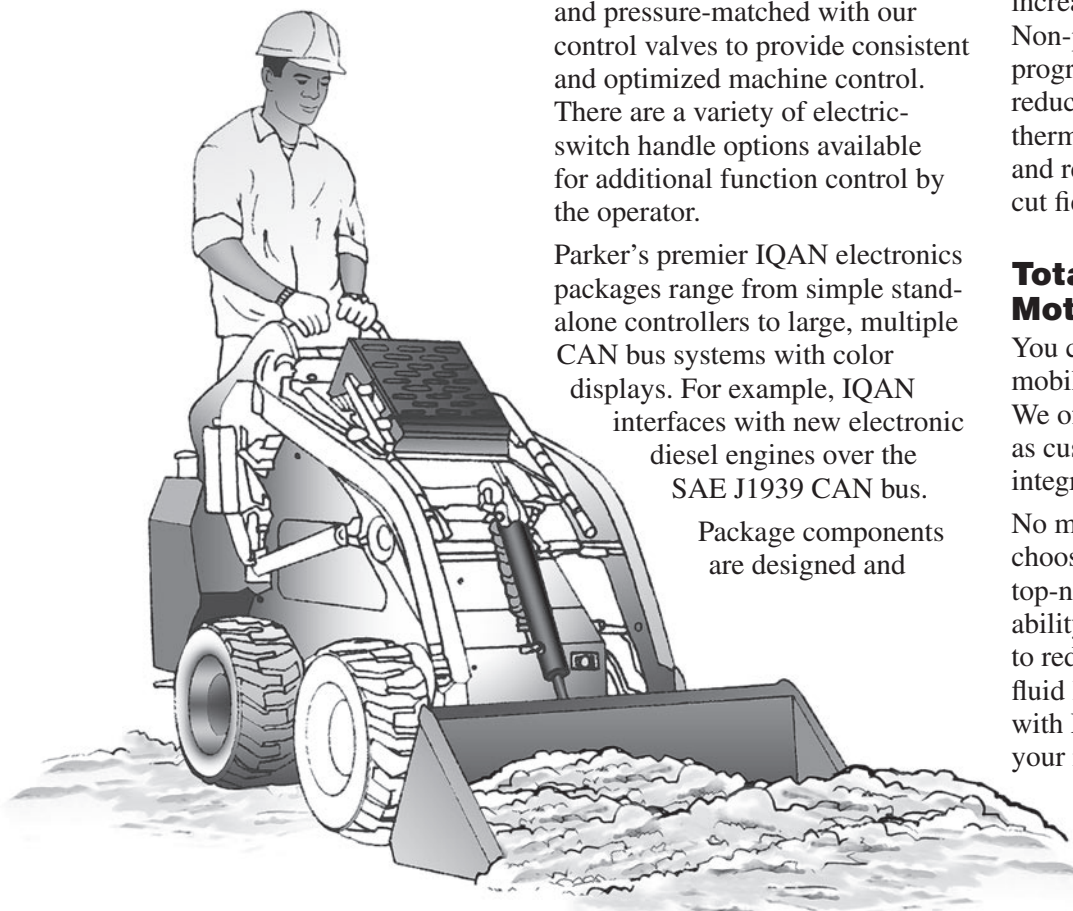

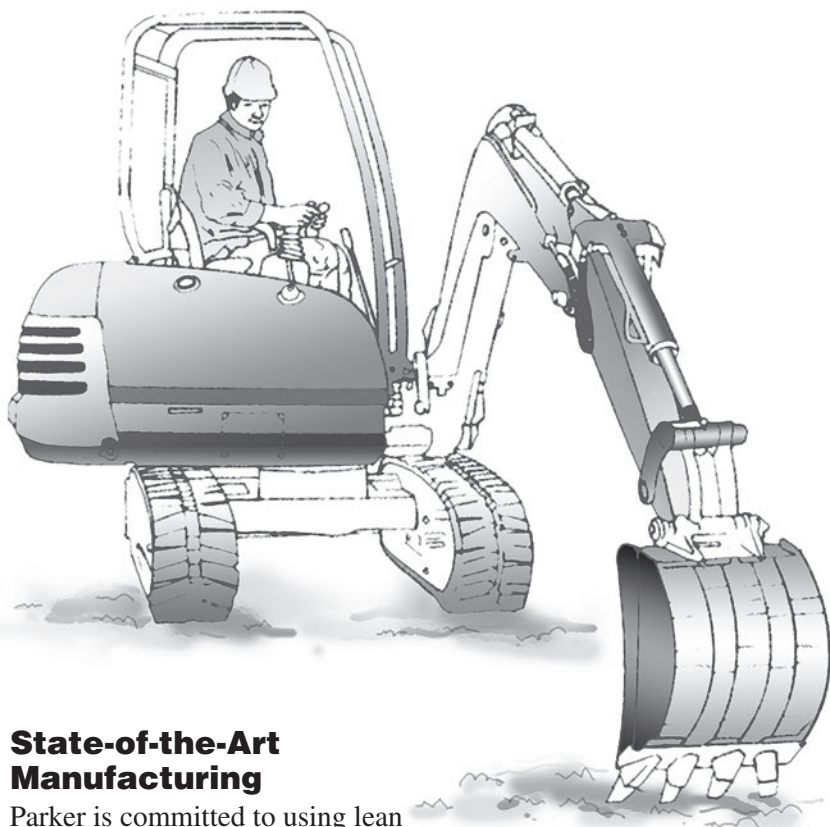

### **State-of-the-Art Manufacturing**

Parker is committed to using lean manufacturing to eliminate waste while streamlining processes. Lean technology helps us meet customer request dates quickly and cost-effectively. We also rely on state-of-the-art equipment and technology, such as computer-aided machining, to ensure product quality.

We regularly invest in our ISO 9001 certified manufacturing facilities because we are committed to meeting all international standards for safety and quality. The hydraulic valves we manufacture comply with relevant ISO, CSA, CE, and AMEX standards.

In addition, Parker hydraulic valves and valve manifolds are fully tested and certified before being released to the customer. You can expect Parker hydraulic valves to work the first time, every time.

### **Customer Service with A Global Reach**

Parker's worldwide network of field sales engineers and Mobile Systems Engineers (MSEs) are the best in the business. A field sales engineer works closely with you, acting as a single point of contact to evaluate applications and design solutions. MSEs support field sales efforts by managing difficult design problems and complex circuit design.

You also benefit from Parker Mobile Technology Centers (MTCs) that are staffed by specially trained distributors who provide only the highest levels of customer service. These one-stop shops offer complete hydraulic systems design for mobile applications, as well as technology services such as diagnostics, troubleshooting, computer design, testing, and integration of electronic controls.

Finally, our thousands of dependable distributors are strategically located in your markets. They carry inventory to meet specific, local market needs, and they ensure that products arrive when and where they are needed. You can count on Parker distributors to minimize downtime.

To locate your nearest distributor for the latest information on the VO40 Directional Control Valve, or our entire mobile valve line-up, visit us at [www.parker.com](http://www.parker.com).

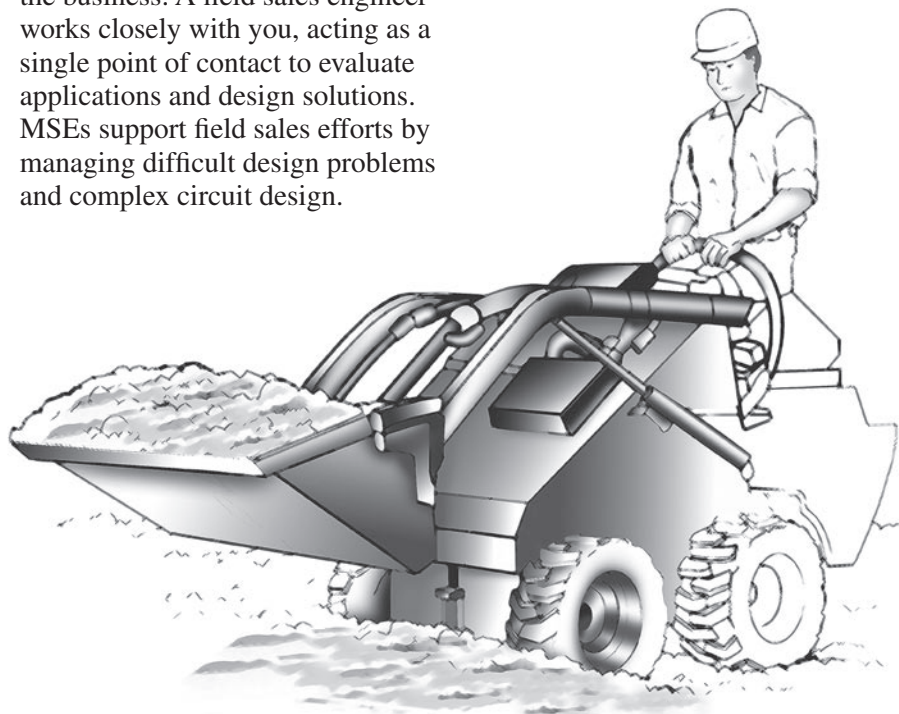

## General Description

The VO40 is an open-center directional control valve with the flexibility of sectional construction. Consistent with this technology, it is simple in its application, reliable, easy to troubleshoot, and cost effective. The global design reflects the performance and quality expected by today's machine designers. Spools have metering notches in the three critical areas – open-center, parallel path and tank, which optimizes simultaneous metering. Contemporary honing technology is used to deliver low work port to tank leakage. Additionally, each work section has a transition check to ensure that a load does not “dip” during simultaneous operation. All of these features, plus those listed below, were intended to take machine controllability to the next level.

## Operation

The VO40 incorporates traditional open-center technology. It is usually interfaced with a constant flow pump, whose flow is routed directly to tank when the spools are in neutral. When one or more spools are selected, flow is directed to the actuators. The throttling of that flow depends upon the spool position and the design of the metering notches. Spool notches can be designed to accommodate resistive loads (meter-in) and negative loads (meter-out). To accommodate multiple pump circuits, split flow and combined flow mid inlets are available.

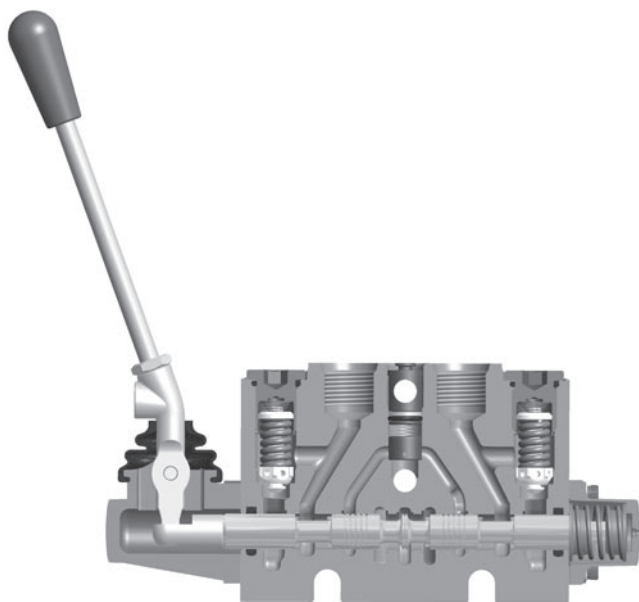

## Benefits

- **Enhanced metering** – especially during simultaneous operation, this is accomplished by having notches in the three critical areas of the spool: open center, parallel path and tank.
- **Improved simultaneous metering** – having a transition check in each work section ensures that a load does not “dip” downward when metering two or more work-sections.
- **Repeatability** – consistent metering from valve to valve is achieved by flycutting all of the critical cast lands. This means that the notch position relative to the spool stroke is controlled and predictable. The result is consistent machine control.
- **Reduced operator fatigue** – the open-center core is a split wing or “Y” core design, which provides for a consistent lever force when selecting the spool from neutral to both power positions.
- **Reduced function drift** – low internal leakage accomplished thru the use of contemporary honing technology. Also, for those functions requiring near zero drift, pilot-operated checks are available.
- **Small footprint** – port accessories are installed vertical to the spool, allowing the handle to be positioned closer to the valve body.
- **Ease of service** – the bottom two stud assemblies are slotted, enabling a work section to be replaced without completely disassembling the valve assembly. This is accomplished by loosening the top tie bolt and then lifting the section out of the assembly. Downtime is minimized.
- **Easy conversion from a left-handed to a right-handed section** – the work section housing and spool are symmetrical, which enables the spool to be inserted in either end of the housing.
- **Improved spool seal life** – the enclosed handle assembly protects the spool and spool seal area from contamination and the potential corrosion.

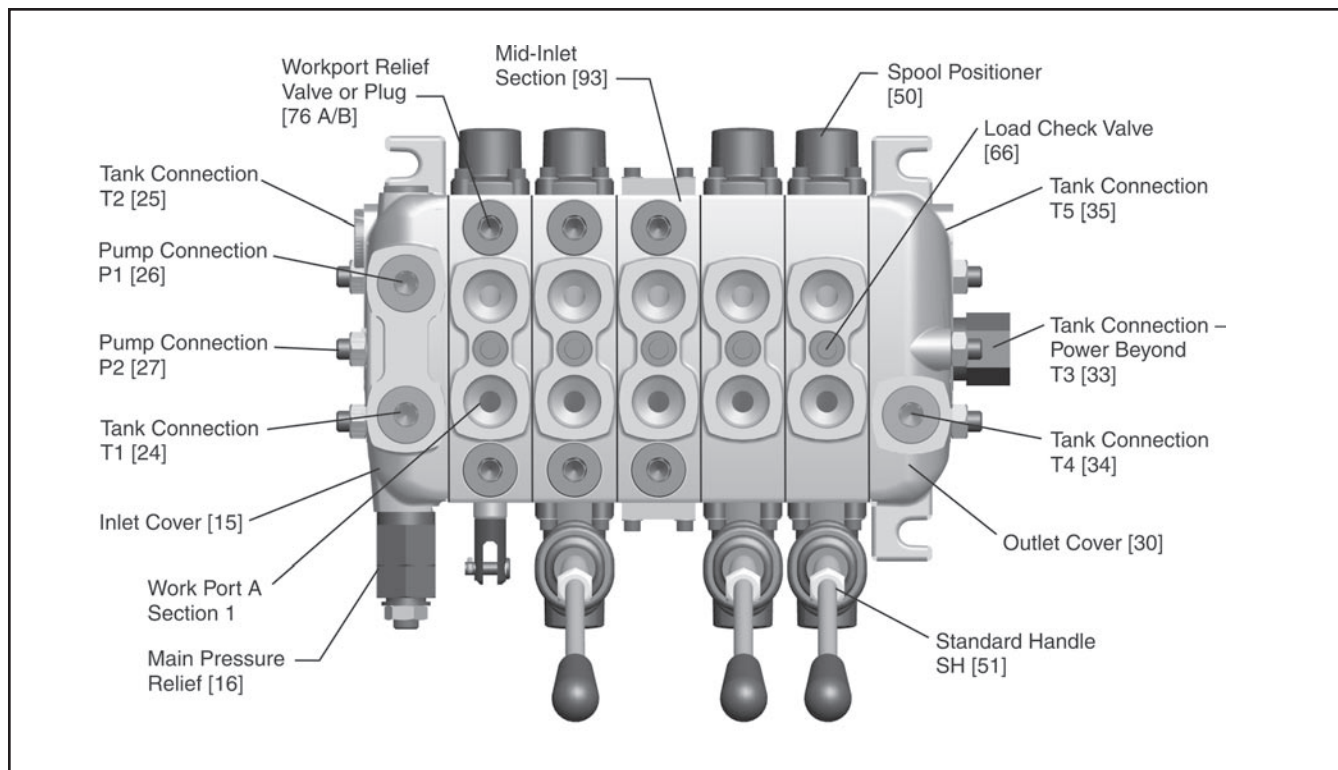

### Specifications

<b>Pressures</b>	Inlet Port: 300 Bar (4350 PSI) Tank Port: 50 Bar (725 PSI) Work Ports: 300 Bar (4350 PSI)
<b>Flow Rates (maximum recommended)</b>	40 LPM (10.6 GPM)
<b>Internal Pilot Pressure</b>	Required for solenoids – consult factory
<b>Spool Leakage from work port to tank</b>	Max. 6 mL/min @ 172 Bar (2500 PSI) Oil temp. 50°C (122°F), and viscosity 40 cSt

### Weights

Weights are approximate due to number of variations available

Inlet with relief	1.92 kg (4.2 lbs)
Outlet	1.88 kg (4.1 lbs)
Work section with reliefs and manual actuator	1.93 kg (4.3 lbs)
Work section and manual actuator without reliefs	1.98 kg (4.4 lbs)
Work Section, PO Checks with manual actuator	2.1 kg (4.6 lbs)
Joystick assembly	0.8 kg (1.8 lbs)

### Connections

Standard valves are available in SAE-6 or SAE-8 (J1926/1). Also available in 3/8" BSP (DIN 3852/2).

Connection	Location	SAE -8	SAE-6	BSP
P1, P2	Inlet	3/4-16 UNF	9/16-18 UNF	3/8-19
T1, T2	Inlet	3/4-16 UNF	9/16-18 UNF	3/8-19
P3	Outlet	3/4-16 UNF	9/16-18 UNF	3/8-19
T3	Outlet	3/4-16 UNF	9/16-18 UNF	3/8-19
PB1	Outlet	3/4-16 UNF	9/16-18 UNF	3/8-19
Work Ports	Work Sections	3/4-16 UNF	9/16-18 UNF	3/8-19
GAGE PORT	Inlet	7/16-20 UNF	7/16-20 UNF	1/4
PC (Hyd. Conn.)	Work Sections	7/16-20 UNF	7/16-20 UNF	1/4
PT (Pneu.Conn.)	Work Sections	1/8 NPT	1/8 NPT	1/8 NPT

**Performance Curves**

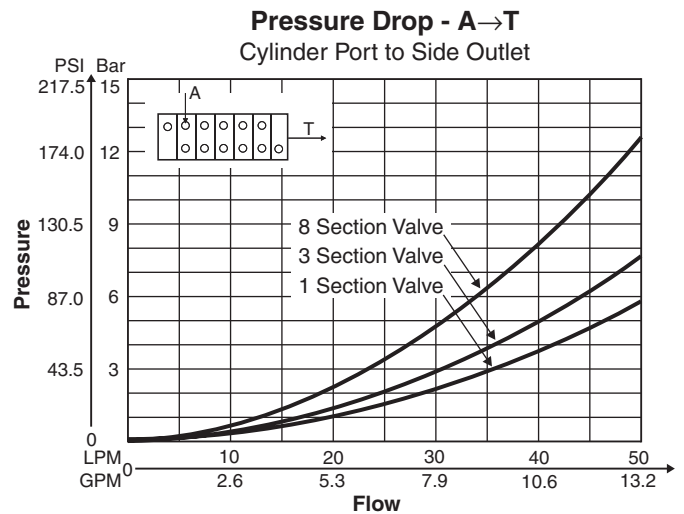
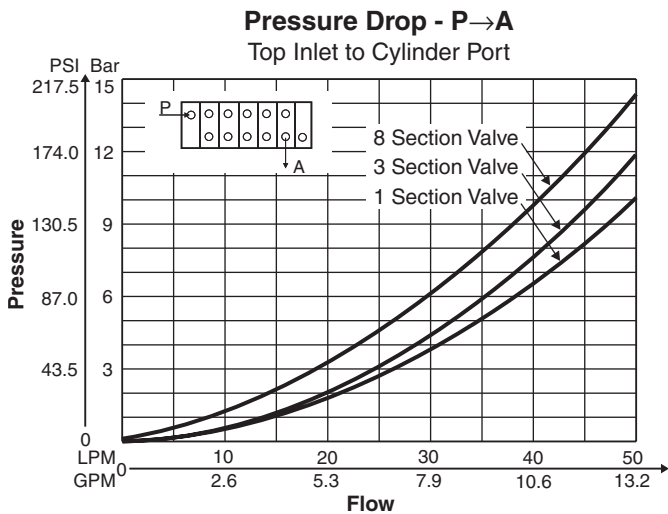
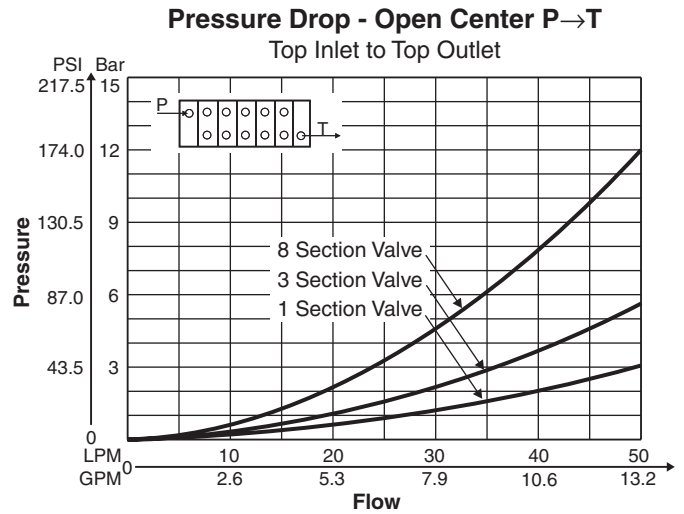
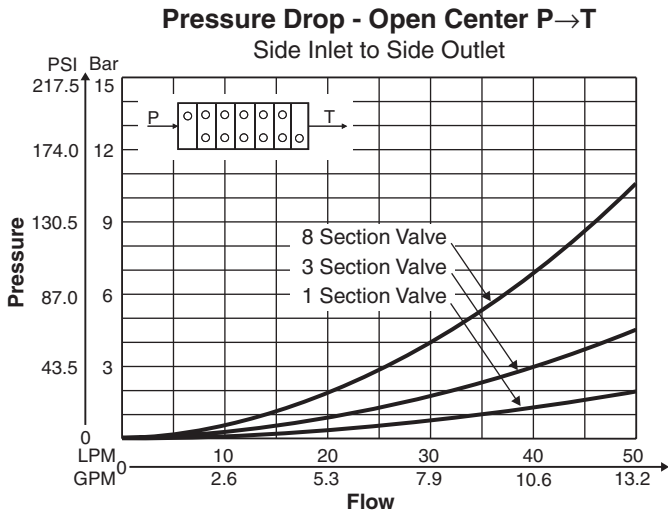

NOTE: ISO VG 46 oil @ 50°C

**Environmental Characteristics**

The valve can be mounted in all conceivable directions. However, the mounting base should be flat and stable so that the valve is not subjected to strain.

While the o-rings in the valve are normally of nitrile rubber, there are a number of special fluorocarbon variants. Please contact Parker for further information.

**Temperature**

Oil temperature, working range:  
 +20°C to 90°C (68 to 194°F)\*

**Filtration**

Filtration must be arranged so that Target Contamination Class 20/18/14 according to ISO 4406 is not exceeded. For the pilot circuit, Target Contamination Class 18/16/13 according to ISO 4406 must not be exceeded.

**Hydraulic Fluids**

Best performance is obtained using mineral-base oil of high quality and cleanliness in the hydraulic system.

Hydraulic fluids of type HLP (DIN 51524), oil for automatic gearboxes Type A and engine oil type API CD can be used.

Viscosity, working range: 15-380 mm<sup>2</sup>/s (15-380 cST)\*\*

**Technical information in this catalog is applicable at an oil viscosity of 30 mm<sup>2</sup>/s (30 cST) and temperature of 50°C (122°F) using nitrile rubber seals.**

\* Product operating limits are broadly within the above range, but satisfactory operation within the specification may not be accomplished. Leakage and response will be affected when used at temperature extremes and it is up to the user to determine acceptability at these levels.

\*\* Performance efficiency will be reduced if outside the ideal values. These extreme conditions must be evaluated by the user to establish suitability of the product's performance.



**Circuit Types – Parallel Circuit**

In the open-center parallel circuit, oil flows through the open-center passage when all of the spools are in neutral. When spools are shifted, oil is diverted into the parallel path and available to each of the selected work-sections. Simultaneous operation can be achieved, when two or more spools are selected. However, since oil will take the path of least resistance the operator must meter the flow to each function to get a desired function speed.

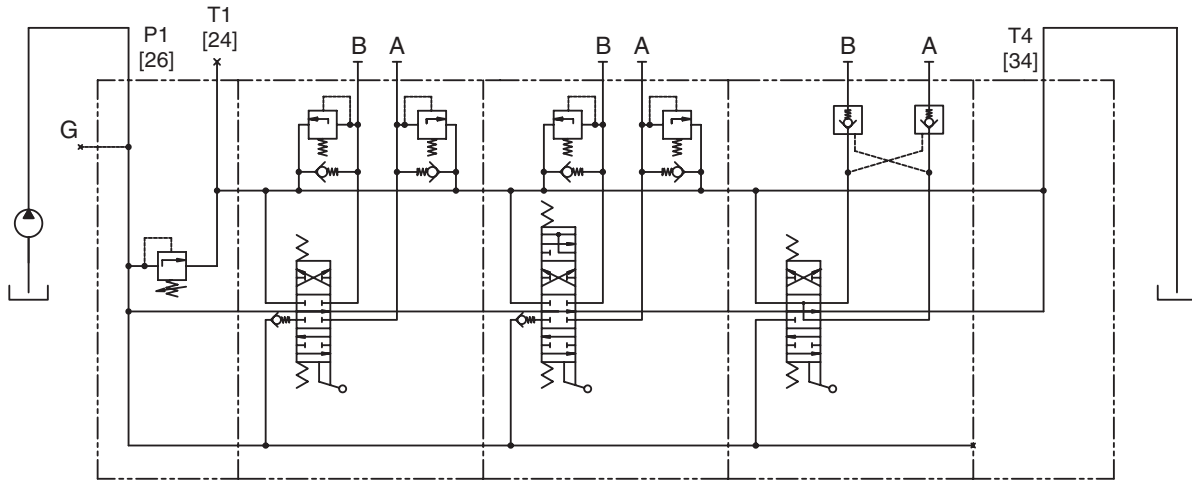

**Circuit Types – Tandem Circuit (Priority)**

In the open-center tandem circuit, oil flows through the open-center passage when all of the spools are in neutral. Tandem work-sections are fed from the open center and the parallel path is blocked. A tandem work-section will give priority to an upstream work-section.

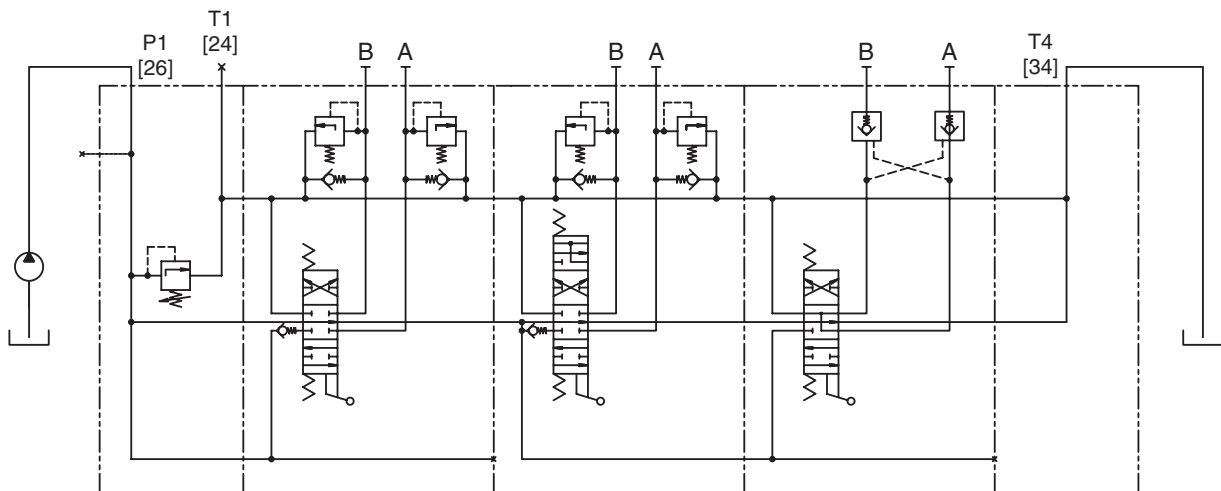

Inch equivalents for millimeter dimensions are shown in (\*\*)

**Assembly**

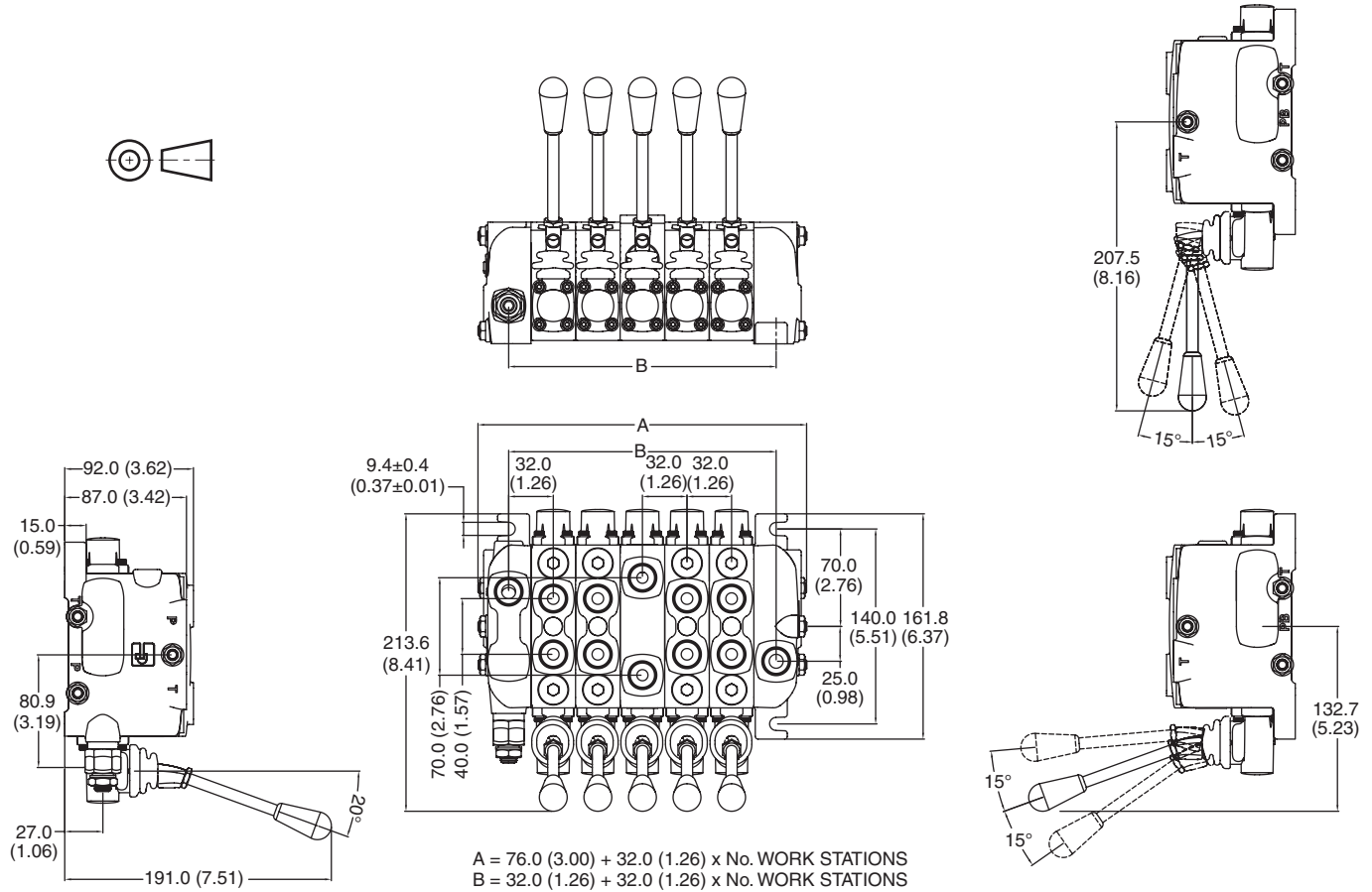

**Spool Stroke of Work Sections**

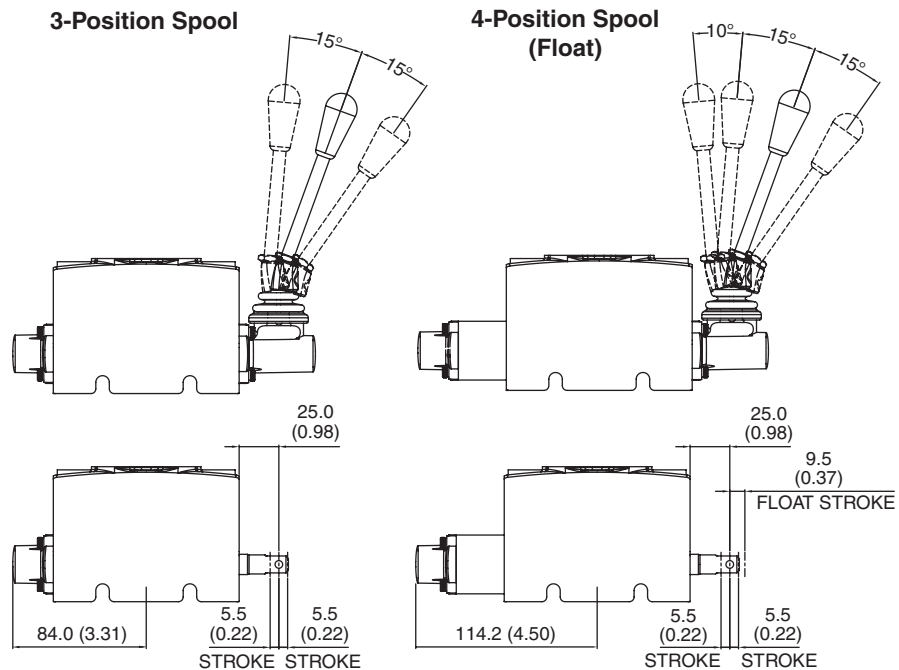

**Dimensions**

Inch equivalents for millimeter dimensions are shown in (\*\*)

**Mechanical Joystick**

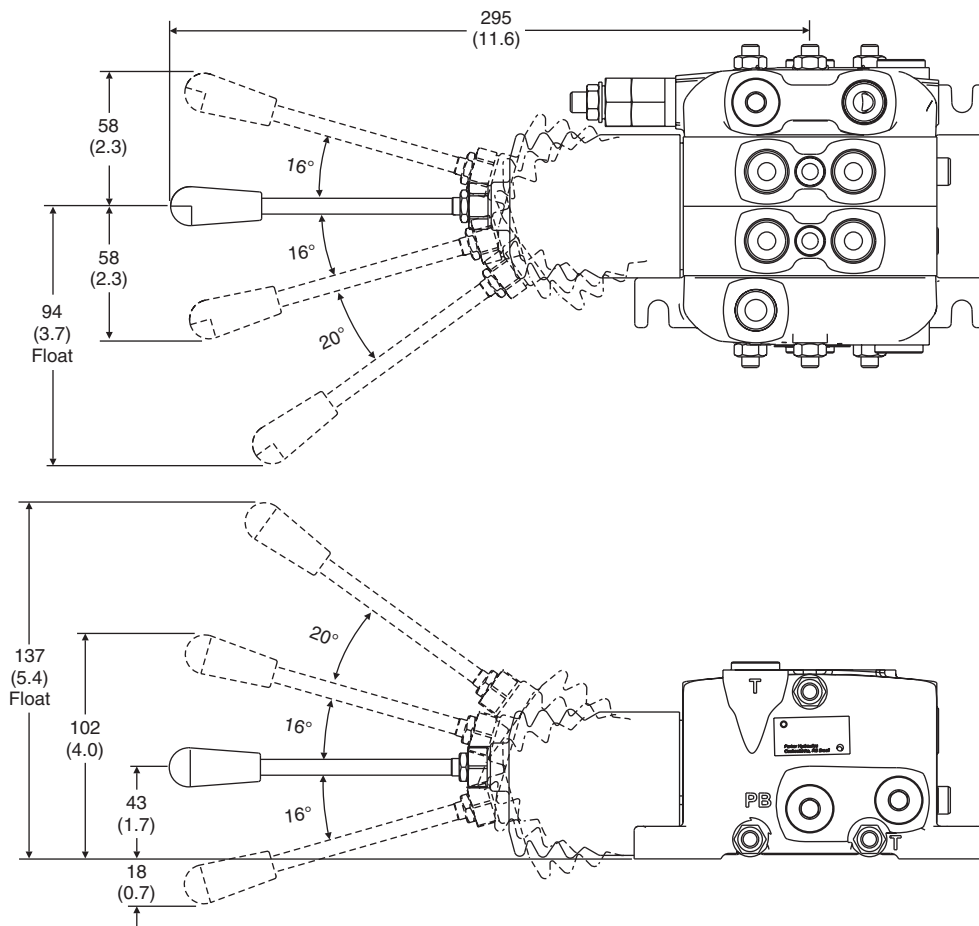

**Pneumatic Actuator**

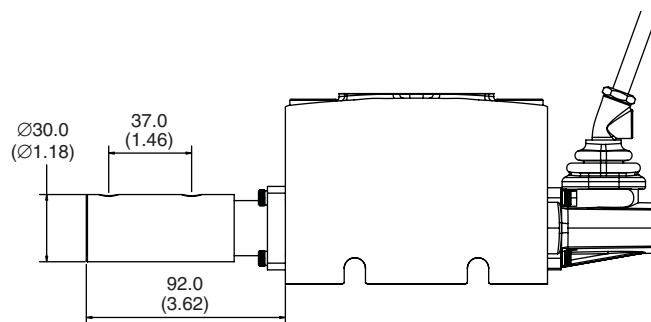

**Dual Actuator**

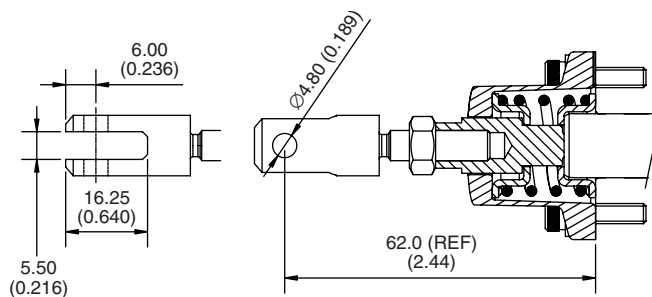

**Handle Actuation vs. Spool Direction**



- Spool Out
- Energize port "B"
- Port "A" to tank



- Spool In
- Energize port "A"
- Port "B" to tank

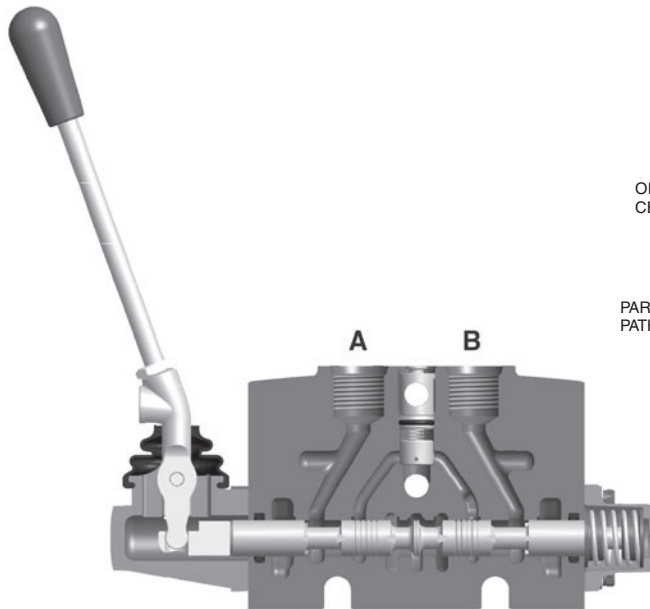

**Upstream View**

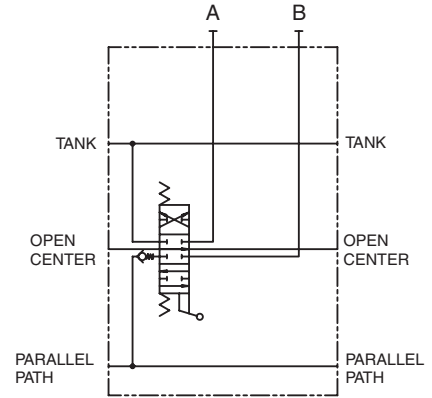

**Note:**  
 Circuit reflects spool position, not handle position

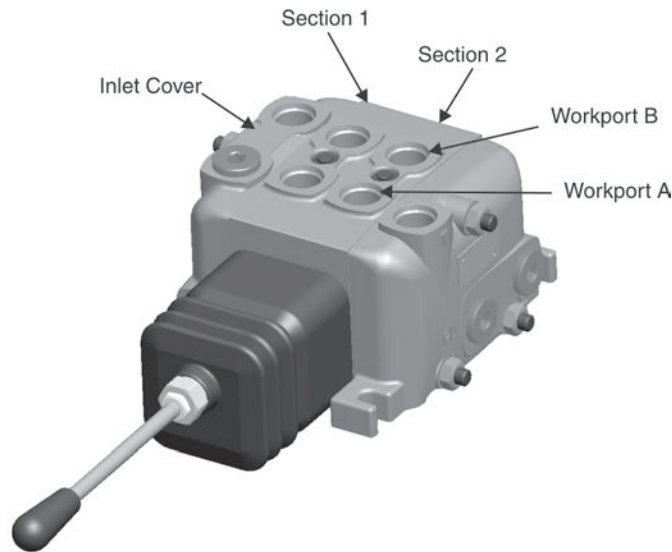

**Left-Hand Joystick**

Spool OUT - Section 1  
 Power to "B" Port

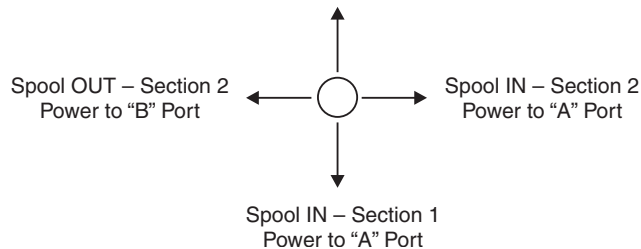

**Right-Hand Joystick**

Spool OUT - Section 2  
 Power to "B" Port

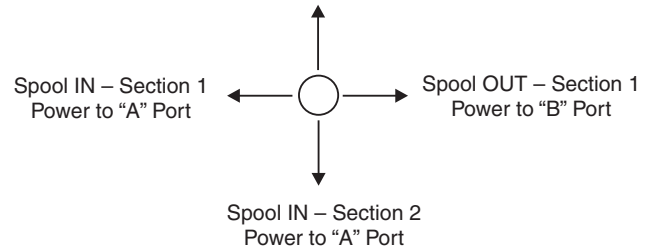

**How to Order the VO40 Valve Assembly**

A specification sheet is located in the back of this book, and is also available in an electronic Excel format on our web site. This form should be used to configure a valve assembly. The layout starts from the inlet cover on the left, work sections and mid-inlets in the middle and the outlet cover on the far right. Each field will require an entry, and the fields are represented with a position reference [ ] to help guide you to the option codes listed in the catalog pages 11 to 21.

**Inlet Cover Portion of Spec Sheet**

Code Position Reference

Customer Information

Section Number starting with the Inlet Cover

CUSTOMER			
CITY:		STATE:	
DATE:		FILLED BY:	
[04] CONNECTIONS THREAD	<b>U8</b>	G = ALL PORTS 3/8" BSP U = ALL PORTS 9/16" UNF (SAE #6) U8 = ALL PORTS 3/4" UNF (SAE #8) U6 = P AND T 3/4" UNF AND WORK PORTS 9/16" UNF	

STACK POS		# 1	# 2	
<b>INLET</b>			<b>WORK SECTION</b>	
pos	description		pos	description
12	Max. Inlet flow (GPM)	<b>6</b>	47	Circuit type
15	Type of Inlet	<b>I</b>	50	Spool actuator
16	Main relief valve	<b>PB</b>	51	Lever Bracket / handle
17	Pressure setting (PSI)	<b>2000</b>	51C	Clevis or Handle location
17C	Relief Flow Setting (GPM)	<b>6</b>	52	Spool pos. indication
24	Tank connection T1	<b>T1</b>	60	Spool function
25	Tank connection T2	<b>T2B</b>	62	Piston head side
26	Pump connection P1	<b>P1B</b>	76A	Port A valve
27	Pump connection P2	<b>P2</b>	76B	Port B valve
<b>P/N SECTION</b>			88A	Restrictor on port A
<b>P/N MCH. CAST</b>			88B	Restrictor on port B
			<b>SPACER SECTION</b>	
			90	Spacer Section
			<b>MID INLET</b>	
			93	Mid Inlet type
			94	Main relief valve
			98	Pressure setting (PSI)
			98C	Relief Flow Setting (GPM)

**Example: Inlet Cover (Sect #1)**

Customer has 6 GPM pump flow, requires a pilot operated main relief set @ 2000 PSI, and wants all SAE-8 work ports.

- Reference position [4] calls out the thread option for the entire valve assembly (SAE or BSP) (“**U8**” is the code for all SAE-8 size ports).
- Note:** There is a separate specification sheet which utilizes metric units.
- Reference position [12] calls out the system flow and can be listed in GPM or LPM depending on which spec sheet you are using (6 is entered for flow).
- Reference position [15] gives you an option for a standard type inlet “I” or an unloader type inlet cover “IU” (“I” is entered for std inlet cover).
- Reference position [16] indicates the type of main relief valve: (“**PB**” is the code for a pilot operated RV).
- Reference position [17] Enter desired relief valve setting (2000 PSI is entered).
- Reference position [17C] Enter desired flow for relief valve setting (6 GPM is entered).
- Reference position [24-27] calls out the inlet/outlet porting (machined/plugged) options:  
**T1** is the top tank port open  
**T2B** is code for side tank port plugged  
**P1B** is code for top inlet port plugged  
**P2** is code for top inlet port open

## Valve Assembly – General Information

The VO40 has two basic thread versions - UNF (SAE) or BSP.

### [04] – Connections Thread

- G** 3/8 BSP Inlet, Outlet & Work Ports
- U** 9/16" UNF (SAE-6) Inlet, Outlet & Work Ports
- U6** 9/16" UNF (SAE-6) Work Ports, 3/4" UNF (SAE-8) Inlet/Outlet Ports
- U8** 3/4" UNF (SAE-8) Inlet, Outlet & Work Ports

**[05] – System Voltage** To be determined when the solenoid option is released

### [07] – Surface Treatment (Paint)

- X** No Paint
- P** Paint valve black

**[08] – Customer Designated ID:** Enter Customer Part Number

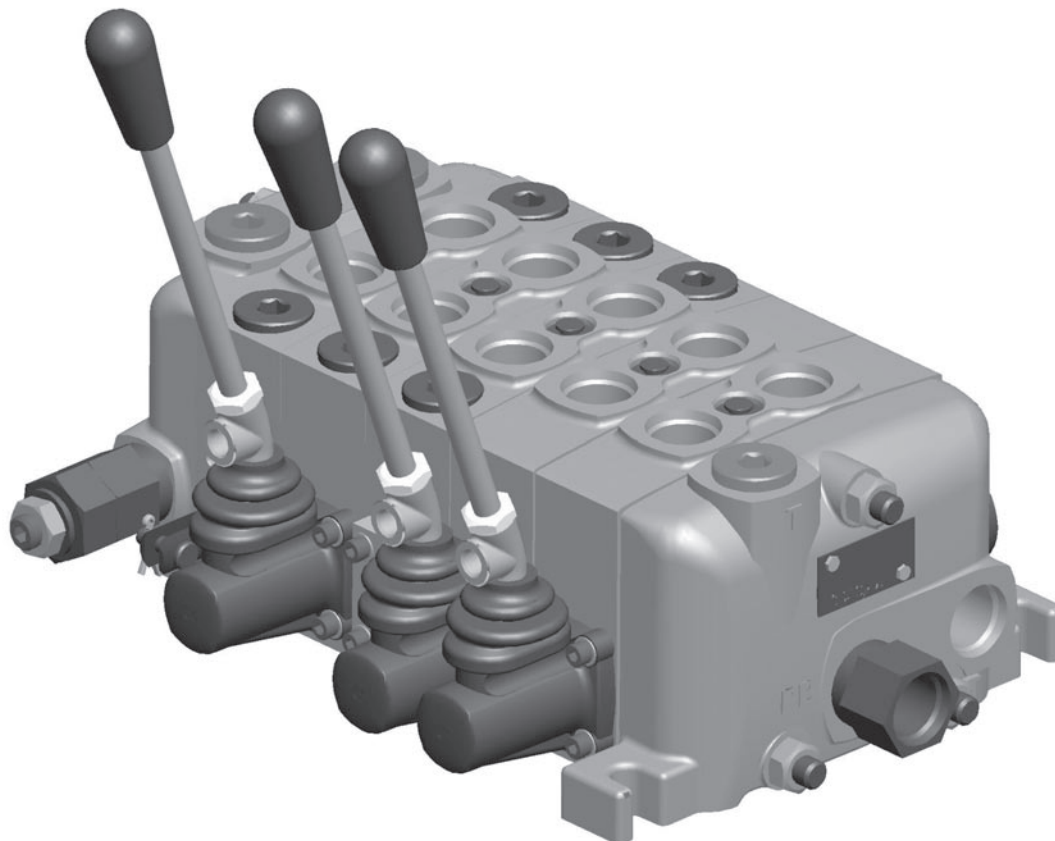

The inlet cover of VO40 is available in two versions. One is the standard inlet and the other is an inlet with a solenoid pump unloader (in development). The porting location options for the standard inlet are: 1) Top/side – inlet and outlet ports. Any unused ports can be plugged and 2) Top – inlet and outlet ports only.

All inlet bodies have a gage port, that comes plugged. SAE #4 (7/16"x20 UNF thread) or 1/4" BSP.

The coding to specify an inlet cover is accomplished by eight fields, as shown below:

**[12] – Max Pump Flow**

The pump inlet flow can be selected in GPM or LPM

**[15] – Type of Inlet**

**I** Standard Inlet

**IU** Inlet with pump unload, solenoid actuated (in development)

**[24] to [27] – Inlet Porting Options**

**1) Standard – Top & Side Inlet/Outlet Ports**

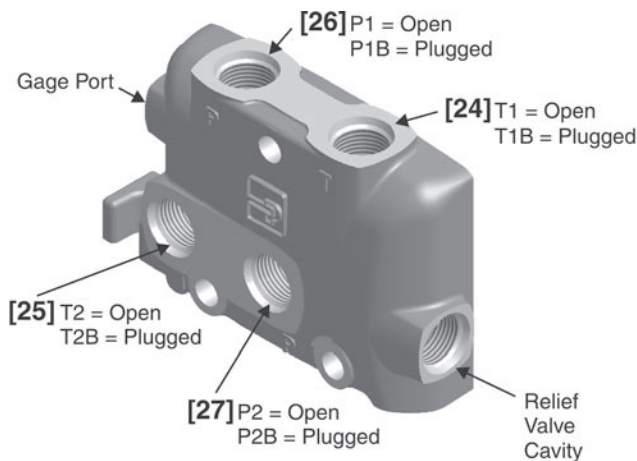

**2) Standard – Top Inlet/Outlet Ports**

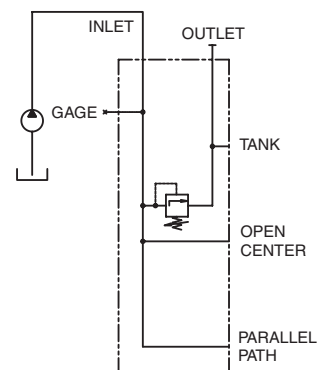
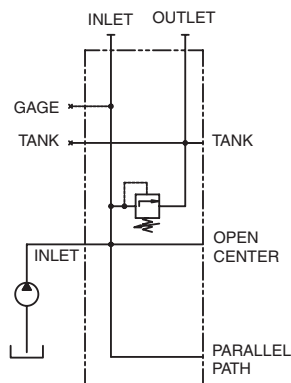
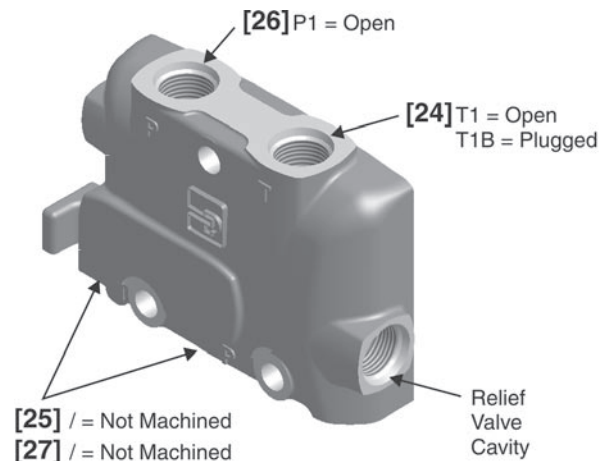

**[16] - Main Relief Options**

**PS** Adjustable main pilot-operated relief  
Adjustment range: 725 to 4300 PSI (50 to 300 Bar)

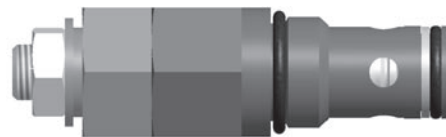

**PB** Adjustable main pilot-operated relief  
(Tamperproof aluminum cap)  
Adjustment range: 725 to 4300 PSI (50 to 300 Bar)



**PN** Adjustable main direct-acting relief  
Adjustment range: 900 to 3000 PSI (60 to 207 Bar)



**PA** Adjustable main direct-acting relief  
(Tamperproof aluminum cap)  
Adjustment range: 900 to 3000 PSI (60 to 207 Bar)

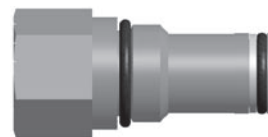

**Y** Not present (cavity machined and plugged)

**[17] – Pressure Setting** – Enter pressure setting (PSI or Bar)

**Note:** Relief valve code PN and PA max setting is 3000 PSI (207 Bar)

**[17C] – Inlet Flow (GPM or LPM)**



The VO40 outlet cover is available in two versions: Standard or with pilot generation and regulation for proportional solenoid applications.

The standard outlet has two porting configurations available: 1) Top and side outlet ports along with machining for conversion to power-beyond or closed-center or 2) Top outlet only.

The coding to specify an outlet is made by four fields as shown below:

**[30] – Type of Outlet**

**US** Standard

**USP** With pilot-pressure generation (to be used on solenoid valves) (in development)

**[33] to [35] – Outlet Porting Options**

**1) Top and Side Outlet Ports**

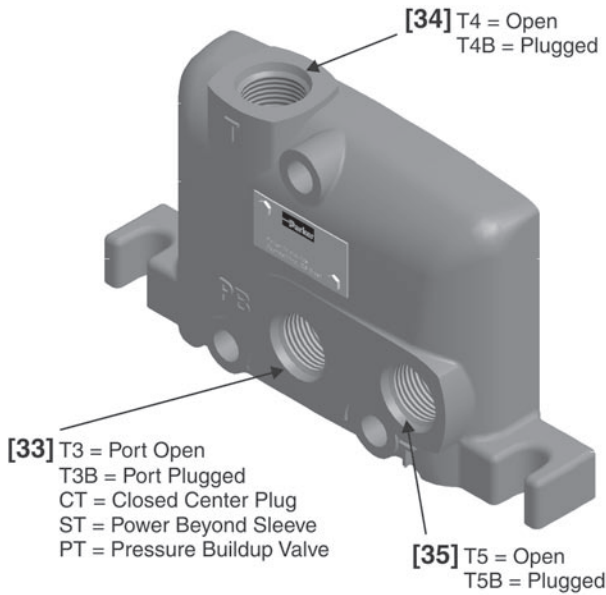

**2) Top Outlet Port Only**

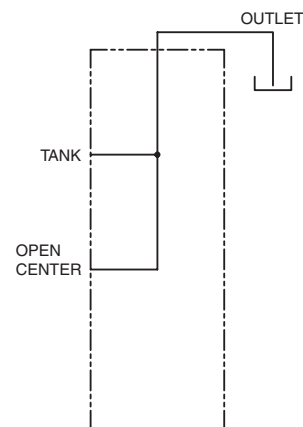
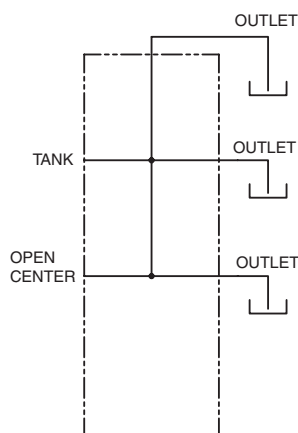
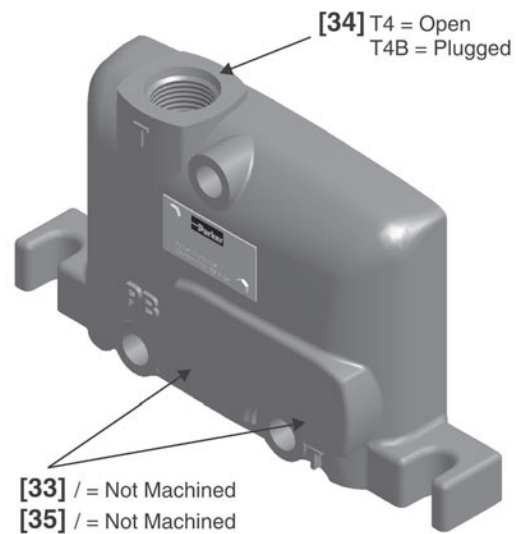

**[33] to [35] – Outlet Porting Options**

**Power-Beyond**

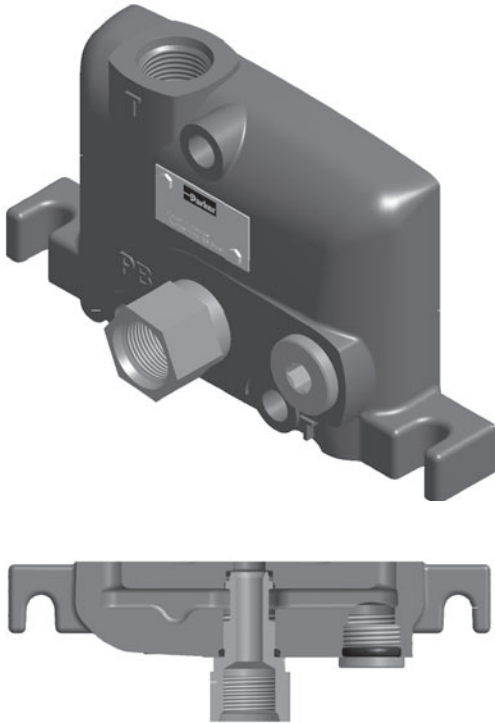

**Closed-Center**

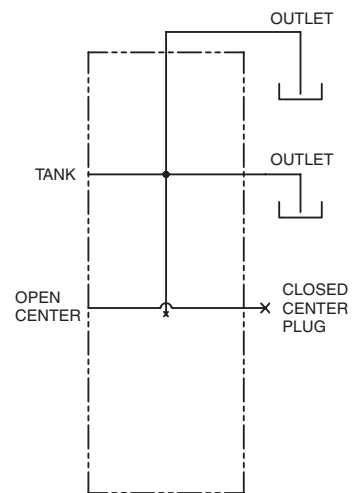
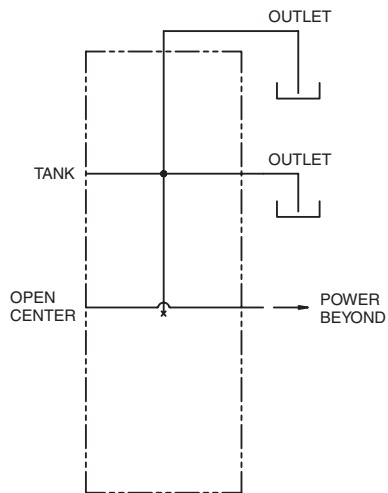
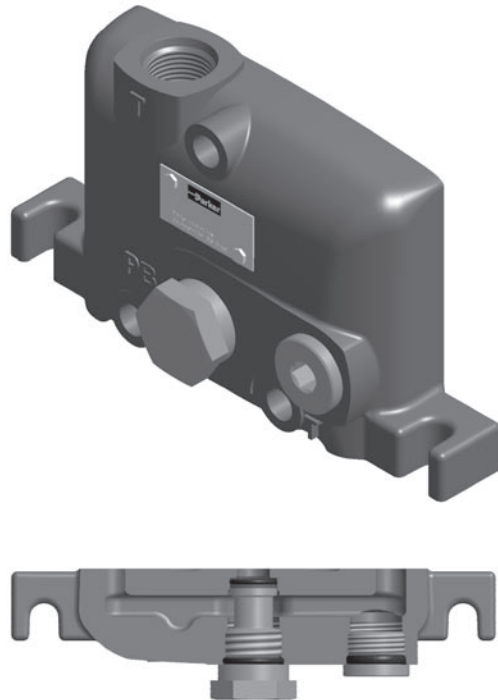

The VO40 valve can be supplied in combinations from one to ten work sections. For each work section there is a variety of spool options, actuators, positioners and port accessories. Work sections can have parallel, series, and/or tandem circuitry. All types can be combined in the same valve assembly.

All work sections with hold in neutral spools have transition checks (load checks). All work sections with free flow in neutral spools (motor) do not include transition checks (load checks). Consult factory if you require a deviation from this configuration.

Work sections are available with or without work port option machining. Integrated pilot-operated checks (Lock-Out) are available in a specially machined casting (ordering code on page 20 [76 A/B]). A spacer section which provides for more spacing between sections is also available (ordering code on page 20 [90]).

### Examples of work port machining options:

**Section without RV Cavities**

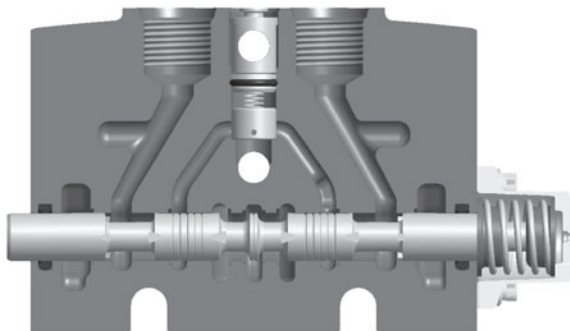

**Section with RV Cavities**

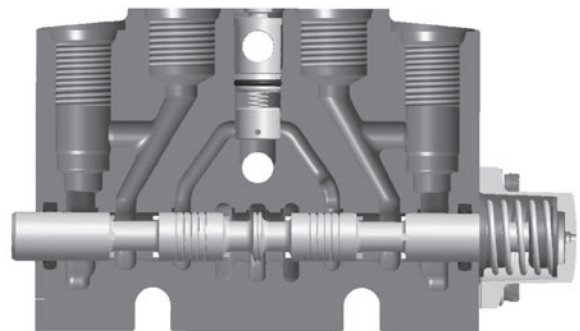

**Section with PO Checks**

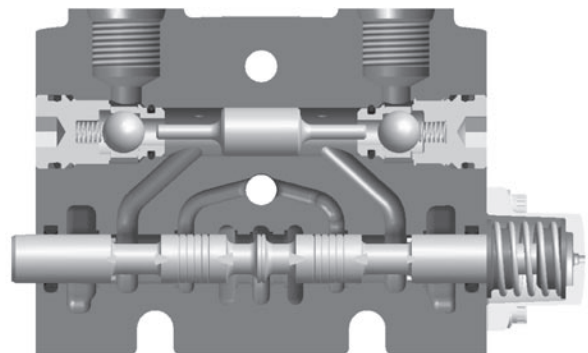

The VO40 Pilot-Operated Check (Lock-Out) sections provide near zero leakage and can prevent cylinder drift when the spool is in the neutral position. When the spool is shifted to a power position, oil is directed to one work port. Return oil is momentarily blocked until pilot pressure unseats the check (3.1:1 ratio). With 3000 PSI load, it will require 968 PSI into the opposite work port to unlock.

The spool is a 4-way, 3-position free flow spool which prevents system pressure leakage from building up and unlocking the PO checks.

The coding to specify a work section is made by 11 fields, as shown below:

### [47] – Work Section Circuitry

- P** Parallel Circuitry
- T** Tandem Circuitry – Provides priority to upstream sections
- S** Series Circuitry– (In development)

[50] – Spool Actuators

**C** Spring centered to neutral position.

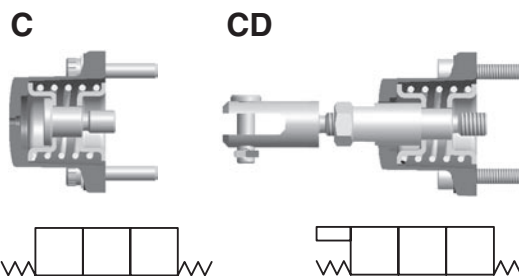

**CD** Spring centered with dual control.

**CHA2** Two position detent – spool “IN”  
Detent in neutral and “A” positions.

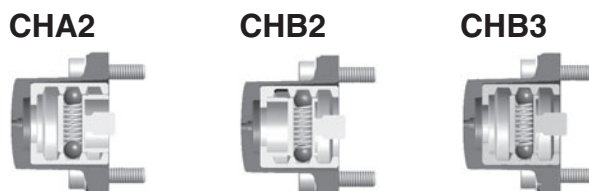

**CHB2** Two position detent – spool “OUT”  
Detent in neutral and “B” positions.

**CHB3** Three position detent.



**B2A** Spring centered with “IN” detent.  
Detent in “A” position and spring centering to neutral position.

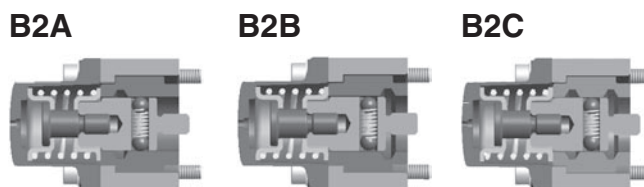

**B2B** Spring centered with “OUT” detent.  
Detent in “B” position and spring centering to neutral position.

**B2C** Spring centered with detent in two positions “A” & “B”.

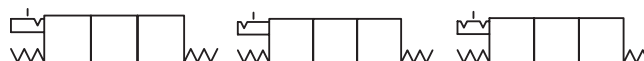

**CB** Spring centered with detent in fourth position, used with float spool.

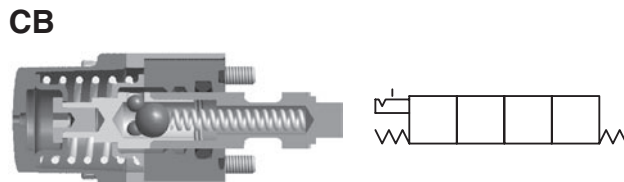

**PC** Hydraulic Remote Actuator (in development)

**EC** Solenoid Operated – Proportional (in development)

**ED** Solenoid Operated – On/Off (in development)

**ACP** Pneumatic actuator – single ended

The pneumatic actuator for the VO40 allows the spool to be operated by a pneumatic signal. The pneumatic actuator is assembled onto one side of the work section and the opposite end is open and available for the addition of a handle. A min. of 80 PSI (5.5 Bar) is required. The threaded ports are both 1/8" NPT.

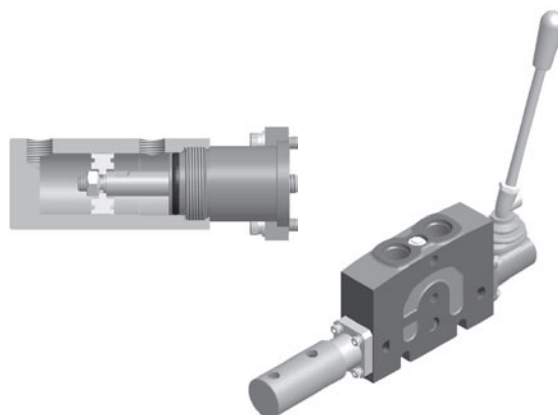

**[51] – Lever Bracket** Note: Handle Levers are sold separately (see PN listed below)

**SH** Standard enclosed handle bracket.

**SR** Standard enclosed handle bracket, but rotated 180 degrees.

**/** No bracket, no handle, no boot (female clevis on spool).

**LU** No bracket, but with boot protector at spool end (female clevis on spool).

**MJL** Mechanical Joystick – left side version (must be placed on two adjacent work sections).

**MJR** Mechanical Joystick – right side version (must be placed on two adjacent work sections).

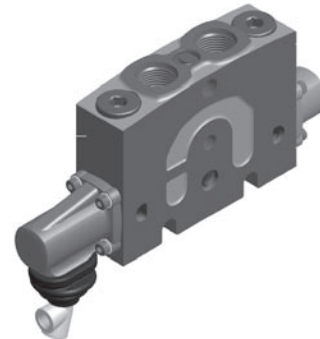
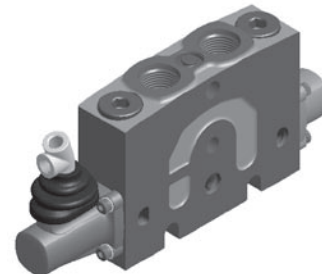

**Handle Rod Assembly** is sold as a separate line item PN: K-VO40-H1



**[51C] – Spool Clevis or Handle Bracket Location**

This field is used to indicate the location of the handle lever and bracket assembly – adjacent to port “A” or port “B” side of the work section.

**A** Spool Clevis or Handle Bracket on port “A” side.

**B** Spool Clevis or Handle Bracket on port “B” side.

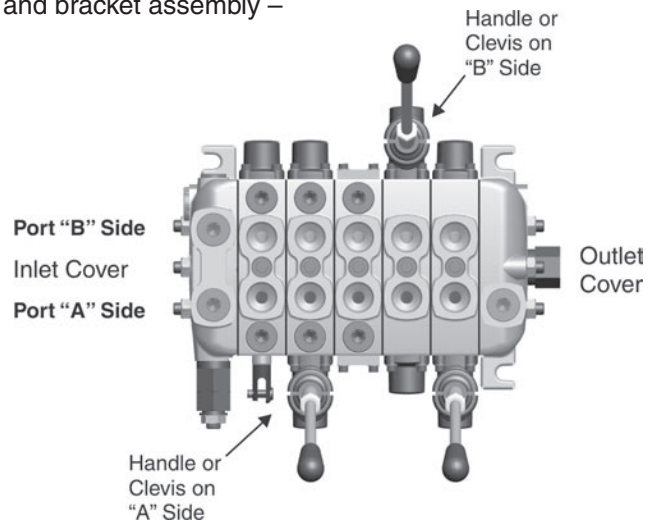

**[52] – Spool Position Indication**

**/** Without spool position indicator.

**SD** With micro-switch on-off indicator (in development)

**[60] – Spool Function**

**D** Double-acting (4-way) spool. Work ports blocked in the neutral position.

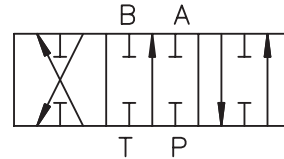

**EA** Single-acting (3-way) spool. Port “A” blocked in neutral. Port “A” is active and Port “B” is plugged.

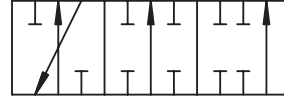

**EB** Single-acting (3-way) spool. Port “B” blocked in neutral. Port “B” is active and Port “A” is plugged.

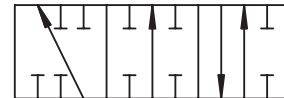

**M** Double-acting (4-way) spool. Work ports open to tank in the neutral position. Note: A work section with this spool does not have a transition check (load check).

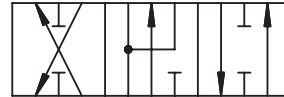

**F** Double-acting (4-way) spool with a 4th position in which both work ports are connected to tank (float position). Work ports are blocked in the neutral position.

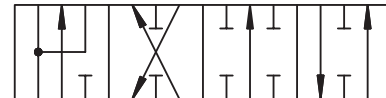

**DM** Double-acting (4-way) spool. Work port pressure is bled to tank, when the spool is in the neutral position.

Bleed notch is designed for 0.5 GPM @ 1000 PSI  
(1.9 LPM @ 69 Bar)

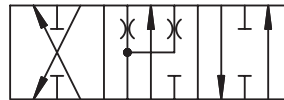

**DA** Double-acting (4-way) spool. Work port “A” pressure is bled to tank, when the spool is in the neutral position

Bleed notch is designed for 0.5 GPM @ 1000 PSI  
(1.9 LPM @ 69 Bar)

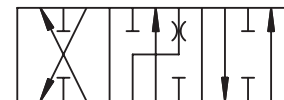

**DB** Double-acting (4-way) spool. Work port “B” pressure is bled to tank, when the spool is in the neutral position

Bleed notch is designed for 0.5 GPM @ 1000 PSI  
(1.9 LPM @ 69 Bar)

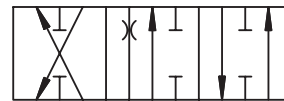

**[62] – Piston Head Side of Cylinder**

The default for this field is code M. Codes A and B are only used when asymmetrical spools must be developed. For example, a cylinder that requires meter-in for one direction and meter-out for the other.

- M** Standard symmetrical spool- cylinder or motor.
- A** Piston head connected with port “A”.
- B** Piston head connected with port “B”.

**[76 A/B] – Work Port Valves**

This pertains to the work port accessory options.

- /** Port not machined.
- Y2** Relief Valve cavity plugged.
- N2** Anti-cavitation valve.
- ( )** RV/AC Non-Adjustable: Enter Pressure setting (PSI or Bar).  
**Note:** RV Set at 2.6 GPM (10 LPM)
- C2** Pilot-Operated Checks (Lock-out valve)  
Refer to page 17.

**Anti-Cavitation Check**



**RV/AC Non-Adjustable**



**No Relief Valve Plug**



**[88 A/B] – Work Port Option**

- /** No Restrictor

Work port restrictors restrict flow in one direction and are free flow in the opposite direction.

Restrict flow “out” of actuator “into” work port

- P1** = 1mm (0.040")
- P2** = 2mm (0.080")
- P3** = 3mm (0.120")
- P4** = 4mm (0.160")

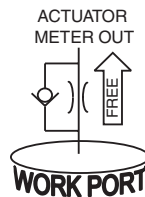

Restrict flow “out” of work port “into” actuator

- N1** = 1mm (0.040")
- N2** = 1mm (0.080")
- N3** = 1mm (0.120")
- N4** = 1mm (0.160")

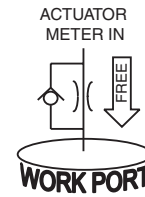

**[90] – Spacer Section**

- N** Spacer Section

This section connects the open center, parallel path and tank cores between two adjacent work sections. This section is used to provide additional spacing between two work sections. All other fields in the work section code can be left blank. (Contact factory for size options available)

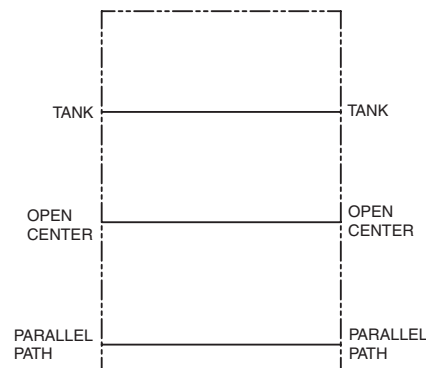

The VO40 mid-inlet options are split or combined flow. They are available with a main RV option. There is also a provision for an outlet port on the split flow version only.

The coding to specify a mid-inlet is made by three fields as shown below:

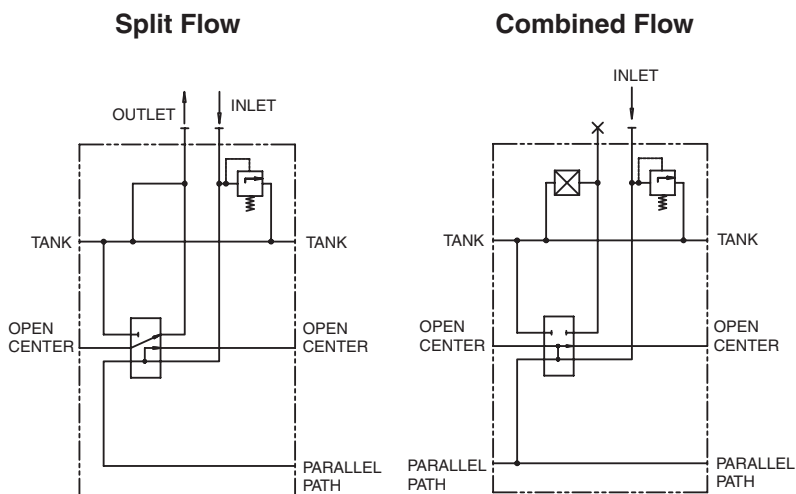
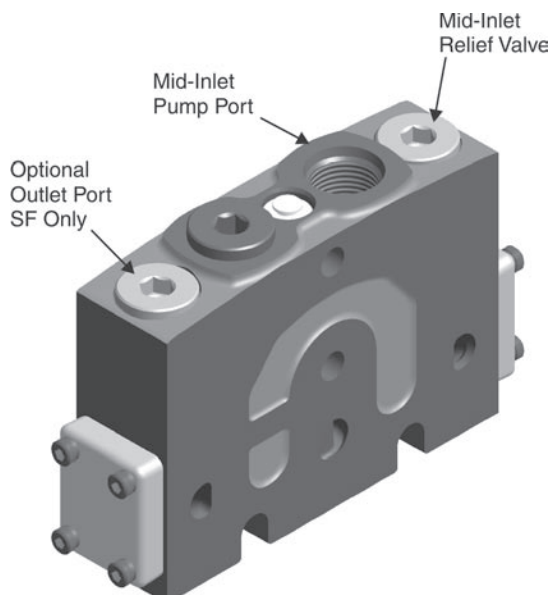

**[93] – Mid Inlet Options**

**C3** Combined Flow (Port “A” inlet - Port “B” is plugged and not available to tank)

**C5** Split Flow (Port “A” inlet - Port “B” is optional tank port)

**[94] – Main Pressure Relief**

**Y** Without pressure relief (cavity machined and plugged)

**PA** Direct-acting relief valve non-adjustable

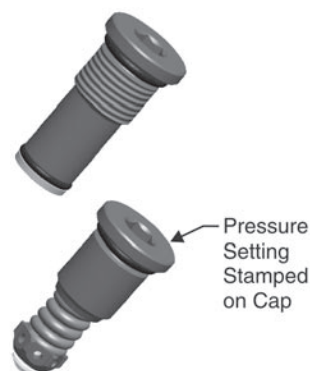

**[98] – Pressure Setting** - Enter pressure (PSI or Bar)

**[98C] – Mid-Inlet Flow (GPM or LPM)**



SHEET 1 DE 1

REVISION
Date
App.
Replace

**PARKER HANNIFIN CORPORATION - HYDRAULIC GROUP**  
 V040 - DIRECTIONAL STACK VALVE - DATA SHEET

P/N

<b>CUSTOMER</b>	<b>APPLICATION</b>
<b>CITY:</b>	<b>CUSTOMER NUMBER:</b>
<b>DATE:</b>	<b>STATE:</b>
<b>FILLED BY:</b>	<b>MAXIMUM FLOW (GPM)</b>
<b>[04] CONNECTIONS THREAD</b>	<b>[05] SYSTEM VOLTAGE</b>
<b>[G - ALL PORTS 3/8" BSP U - ALL PORTS 3/16" UNF (SAE #8) UR - ALL PORTS 3/4" UNF (SAE #8) UR - P AND T 3/4" UNF AND WORK PORTS 9/16" UNF</b>	<b>MAXIMUM PRESSURE (PSI)</b>
	<b>12 = 12 VDC 24 = 24 VDC P = BLACK BASE X = NO PAINTING</b>
	<b>[07] PAINTING</b>
	<b>[08] CUSTOMER DESIGNATED ID:</b>

pos	description	STACK POS										
		# 1	# 2	# 3	# 4	# 5	# 6	# 7	# 8	# 9	# 10	# 11
<b>INLET</b>												
12	Max. Inlet flow (GPM)											
15	Type of Inlet											
16	Main relief valve											
17	Pressure setting (PSI)											
17C	Relief Flow Setting (GPM)											
24	Tank connection T1											
25	Tank connection T2											
26	Pump connection P1											
27	Pump connection P2											
<b>P/N SECTION</b>												
<b>P/N MCH. CAST</b>												
<b>WORK SECTION</b>												
47	Circuit type											
50	Spool actuator											
51	Lever Bracket / handle											
51C	Clevis or Handle location											
52	Spool pos. indication											
60	Spool function											
62	Piston head side											
76A	Port A valve											
76B	Port B valve											
88A	Restrictor on port A											
88B	Restrictor on port B											
<b>SPACER SECTION</b>												
90	Spacer Section											
<b>MID INLET</b>												
93	Mid Inlet type											
94	Main relief valve											
98	Pressure setting (PSI)											
98C	Relief Flow Setting (GPM)											
<b>P/N SECTION</b>												
<b>P/N MACH. CAST</b> (Leave blank if not sure)												
<b>P/N ACCESSORIES</b>												
<b>CONNECTION PORT A</b>												
<b>CONNECTION PORT B</b>												
<b>ASSEMBLING KIT</b>												
<b>PAINTING</b>												

rev.	date	doc	app
A			
B			
C			
D			
E			
F			
G			

**TEST STANDARD:**

**REMARKS:**

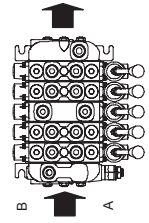
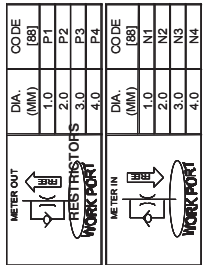

## Offer of Sale

The items described in this document and other documents or descriptions provided by Parker Hannifin Corporation, its subsidiaries and its authorized distributors are hereby offered for sale at prices to be established by Parker Hannifin Corporation, its subsidiaries and its authorized distributors. This offer and its acceptance by any customer ("Buyer") shall be governed by all of the following Terms and Conditions. Buyer's order for any such items, when communicated to Parker Hannifin Corporation, its subsidiary or an authorized distributor ("Seller") verbally or in writing, shall constitute acceptance of this offer.

**1. Terms and Conditions of Sale:** All descriptions, quotations, proposals, offers, acknowledgments, acceptances and sales of Seller's products are subject to and shall be governed exclusively by the terms and conditions stated herein. Buyer's acceptance of any offer to sell is limited to these terms and conditions. Any terms or conditions in addition to, or inconsistent with those stated herein, proposed by Buyer in any acceptance of an offer by Seller, are hereby objected to. No such additional, different or inconsistent terms and conditions shall become part of the contract between Buyer and Seller unless expressly accepted in writing by Seller. Seller's acceptance of any offer to purchase by Buyer is expressly conditional upon Buyer's assent to all the terms and conditions stated herein, including any terms in addition to, or inconsistent with those contained in Buyer's offer. Acceptance of Seller's products shall in all events constitute such assent.

**2. Payment:** Payment shall be made by Buyer net 30 days from the date of delivery of the items purchased hereunder. Amounts not timely paid shall bear interest at the maximum rate permitted by law for each month or portion thereof that the Buyer is late in making payment. Any claims by Buyer for omissions or shortages in a shipment shall be waived unless Seller receives notice thereof within 30 days after Buyer's receipt of the shipment.

**3. Delivery:** Unless otherwise provided on the face hereof, delivery shall be made F.O.B. Seller's plant. Regardless of the method of delivery, however, risk of loss shall pass to Buyer upon Seller's delivery to a carrier. Any delivery dates shown are approximate only and Seller shall have no liability for any delays in delivery.

**4. Warranty:** Seller warrants that the items sold hereunder shall be free from defects in material or workmanship for a period of 18 months from date of shipment from Parker Hannifin Corporation. **THIS WARRANTY COMPRISES THE SOLE AND ENTIRE WARRANTY PERTAINING TO ITEMS PROVIDED HEREUNDER. SELLER MAKES NO OTHER WARRANTY, GUARANTEE, OR REPRESENTATION OF ANY KIND WHATSOEVER. ALL OTHER WARRANTIES, INCLUDING BUT NOT LIMITED TO, MERCHANTABILITY AND FITNESS FOR PURPOSE, WHETHER EXPRESS, IMPLIED, OR ARISING BY OPERATION OF LAW, TRADE USAGE, OR COURSE OF DEALING ARE HEREBY DISCLAIMED. NOTWITHSTANDING THE FOREGOING, THERE ARE NO WARRANTIES WHATSOEVER ON ITEMS BUILT OR ACQUIRED WHOLLY OR PARTIALLY, TO BUYER'S DESIGNS OR SPECIFICATIONS.**

**5. Limitation Of Remedy: SELLER'S LIABILITY ARISING FROM OR IN ANY WAY CONNECTED WITH THE ITEMS SOLD OR THIS CONTRACT SHALL BE LIMITED EXCLUSIVELY TO REPAIR OR REPLACEMENT OF THE ITEMS SOLD OR REFUND OF THE PURCHASE PRICE PAID BY BUYER, AT SELLER'S SOLE OPTION. IN NO EVENT SHALL SELLER BE LIABLE FOR ANY INCIDENTAL, CONSEQUENTIAL OR SPECIAL DAMAGES OF ANY KIND OR NATURE WHATSOEVER, INCLUDING BUT NOT LIMITED TO LOST PROFITS ARISING FROM OR IN ANY WAY CONNECTED WITH THIS AGREEMENT OR ITEMS SOLD HEREUNDER, WHETHER ALLEGED TO ARISE FROM BREACH OF CONTRACT, EXPRESS OR IMPLIED WARRANTY, OR IN TORT, INCLUDING WITHOUT LIMITATION, NEGLIGENCE, FAILURE TO WARN OR STRICT LIABILITY.**

**6. Changes, Reschedules and Cancellations:** Buyer may request to modify the designs or specifications for the items sold hereunder as well as the quantities and delivery dates thereof, or may request to cancel all or part of this order, however, no such requested modification or cancellation shall become part of the contract between Buyer and Seller unless accepted by Seller in a written amendment to this Agreement. Acceptance of any such requested modification or cancellation shall be at Seller's discretion, and shall be upon such terms and conditions as Seller may require.

**7. Special Tooling:** A tooling charge may be imposed for any special tooling, including without limitation, dies, fixtures, molds and patterns, acquired to manufacture items sold pursuant to this contract. Such special tooling shall be and remain Seller's property notwithstanding payment of any charges by Buyer. In no event will Buyer acquire any interest in apparatus belonging to Seller which is utilized in the manufacture of the items sold hereunder, even if such apparatus has been specially converted or adapted for such manufacture and notwithstanding any charges paid by Buyer. Unless otherwise agreed, Seller shall have the right to alter,

discard or otherwise dispose of any special tooling or other property in its sole discretion at any time.

**8. Buyer's Property:** Any designs, tools, patterns, materials, drawings, confidential information or equipment furnished by Buyer or any other items which become Buyer's property, may be considered obsolete and may be destroyed by Seller after two (2) consecutive years have elapsed without Buyer placing an order for the items which are manufactured using such property, Seller shall not be responsible for any loss or damage to such property while it is in Seller's possession or control.

**9. Taxes:** Unless otherwise indicated on the face hereof, all prices and charges are exclusive of excise, sales, use, property, occupational or like taxes which may be imposed by any taxing authority upon the manufacture, sale or delivery of the items sold hereunder. If any such taxes must be paid by Seller or if Seller is liable for the collection of such tax, the amount thereof shall be in addition to the amounts for the items sold. Buyer agrees to pay all such taxes or to reimburse Seller therefore upon receipt of its invoice. If Buyer claims exemption from any sales, use or other tax imposed by any taxing authority, Buyer shall save Seller harmless from and against any such tax, together with any interest or penalties thereon which may be assessed if the items are held to be taxable.

**10. Indemnity For Infringement of Intellectual Property Rights:** Seller shall have no liability for infringement of any patents, trademarks, copyrights, trade dress, trade secrets or similar rights except as provided in this Part 10. Seller will defend and indemnify Buyer against allegations of infringement of U.S. Patents, U.S. Trademarks, copyrights, trade dress and trade secrets (hereinafter 'Intellectual Property Rights'). Seller will defend at its expense and will pay the cost of any settlement or damages awarded in an action brought against Buyer based on an allegation that an item sold pursuant to this contract infringes the Intellectual Property Rights of a third party. Seller's obligation to defend and indemnify Buyer is contingent on Buyer notifying Seller within ten (10) days after Buyer becomes aware of such allegations of infringement, and Seller having sole control over the defense of any allegations or actions including all negotiations for settlement or compromise. If an item sold hereunder is subject to a claim that it infringes the Intellectual Property Rights of a third party, Seller may, at its sole expense and option, procure for Buyer the right to continue using said item, replace or modify said item so as to make it noninfringing, or offer to accept return of said item and return the purchase price less a reasonable allowance for depreciation. Notwithstanding the foregoing, Seller shall have no liability for claims of infringement based on information provided by Buyer, or directed to items delivered hereunder for which the designs are specified in whole or part by Buyer, or infringements resulting from the modification, combination or use in a system of any item sold hereunder. The foregoing provisions of this Part 10 shall constitute Seller's sole and exclusive liability and Buyer's sole and exclusive remedy for infringement of Intellectual Property Rights.

If a claim is based on information provided by Buyer or if the design for an item delivered hereunder is specified in whole or in part by Buyer, Buyer shall defend and indemnify Seller for all costs, expenses or judgments resulting from any claim that such item infringes any patent, trademark, copyright, trade dress, trade secret or any similar right.

**11. Force Majeure:** Seller does not assume the risk of and shall not be liable for delay or failure to perform any of Seller's obligations by reason of circumstances beyond the reasonable control of Seller (hereinafter 'Events of Force Majeure'). Events of Force Majeure shall include without limitation, accidents, acts of God, strikes or labor disputes, acts, laws, rules or regulations of any government or government authority, fires, floods, delays or failures in delivery of carriers or suppliers, shortages of materials and any other cause beyond Seller's control.

**12. Entire Agreement/Governing Law:** The terms and conditions set forth herein, together with any amendments, modifications and any different terms or conditions expressly accepted by Seller in writing, shall constitute the entire Agreement concerning the items sold, and there are no oral or other representations or agreements which pertain thereto. This Agreement shall be governed in all respects by the law of the State of Ohio. No actions arising out of the sale of the items sold hereunder or this Agreement may be brought by either party more than two (2) years after the cause of action accrues.

9/91-P

## Parker Hydraulics International Sales Offices

### North America

#### Hydraulics Group Headquarters

6035 Parkland Boulevard  
Cleveland, OH 44124-4141 USA  
Tel: 216-896-3000  
Fax: 216-896-4031

#### Motion & Control Sales Division

651 Robbins Drive, PO Box 3500  
Troy, MI 48007-3500 USA  
Tel: 248-589-2400  
Fax: 248-577-4890

#### Parker Hannifin Canada

##### Motion & Control Division – Milton

160 Chisholm Drive Milton  
Ontario Canada L9T 3G9  
Tel: 905-693-3011  
Fax: 905-876-0788

##### Motion & Control Division – Montreal

2001 rue de l'aviation  
Dorval, Quebec, H9P 2X6  
Tel: 514-684-3000  
Fax: 514-684-4191

##### Motion & Control Division – Calgary

3141B – 18th Street N.E.  
Calgary, Alberta T2E 7K8  
Tel: 403-291-9284  
Fax: 403-291-9285

#### Mexico

##### Parker Hannifin de Mexico, S.A. C.V

Via de Ferrocarril a Matamoros 730  
Apodaca, N.L. C.P. 66600, Mexico  
Tel: 01-8181-566036 y 96

##### Parker Hannifin de México

Av eje uno norte num 100  
Parque Industrial Toluca 2000  
Toluca, Mex C.P. 50100  
Tel: 52 722 2754200  
Fax: 52 722 2799308

### Mobile Sales

#### Mobile Systems Division

595 Schelter Road  
Suite 100  
Lincolnshire, IL 60069 USA  
Tel: 847-821-1500  
Fax: 847-821-7600

#### Pacific Region

8460 Kass Drive  
Buena Park, CA 90621  
Tel: 714-228-2510  
Fax: 714-228-2511

#### Great Plains Region

931 Alice Court  
St. Charles, IL 60174 USA  
Tel: 630-377-0271  
Fax: 630-377-0271

#### Midwest Region

4494 32nd Street  
Grinnell, IA 50112 USA  
Tel: 641-236-3694  
Fax: 641-236-8884

#### Southern Region

2300 Bush Circle  
Carrollton, TX 75007 USA  
Tel: 972-307-2949  
Fax: 972-307-9410

#### Eastern Region

100 Corporate Drive  
Lebanon, NJ 08833 USA  
Tel: 610-330-0970  
Fax: 925-396-6481

cat hy14-2720.indd, m&a

### Europe

#### Europe Hydraulics Group

##### Parker Hannifin Corporation

Parker House  
55 Maylands Avenue  
Hemel Hempstead, Herts  
HP2 4SJ England  
Tel: 44 1442 458000  
Fax: 44 1442 458085

#### Austria

**Parker Hannifin GmbH**  
Badener Strasse 12  
A-2700 Wiener Neustadt, Austria  
Tel: 43 2622 23501-0  
Fax: 43 2622 66212

#### Belgium

**Parker Hannifin SA NV**  
Parc Industriel Sud, Zone II  
Rue du Bosquet 23  
B-1400 Nivelles, Belgium  
Tel: 32 67 280900  
Fax: 32 67 280999

#### Czech Republic

**Parker Hannifin s.r.o.**  
Parkerova 623  
250 67 Klecany, Czech Republic  
Tel: 420 284 083 111  
Fax: 420 284 083 112

#### Denmark

**Parker Hannifin Denmark A/S**  
Industriparken 37  
2750 Ballerup, Denmark  
Tel: 45 43 56 04 00  
Fax: 45 43 73 31 07

#### Finland

**Parker Hannifin Oy**  
Ylästöntie 16  
FIN-01510 Vantaa, Finland  
Tel: 358 9 476 731  
Fax: 358 9 4767 3200

#### France

**Parker Hannifin France SAS**  
142, rue de la Foret  
74130 Contamine sur Arve, France  
Tel: 33 450 25 80 25  
Fax: 33 450 03 67 37

#### Germany/Switzerland

**Parker Hannifin GmbH & Co. KG**  
Pat-Parker-Platz 1  
41564 Kaarst, Germany  
Tel: 49 (0) 2131 4016 0  
Fax: 49 (0) 2131 4016 9199

#### Greece

**Parker Hannifin Corporation  
Athens Representative Office**  
197 Syngrou Av.  
171 21 Nea Smyrni, Athens, Greece  
Tel: 0030 210 933-6450  
Fax: 0030 210 933-6451

#### Hungary

**Parker Hannifin Corporation  
Hungarian Trade Representative Office**  
H-1149 Budapest  
Egressy u. 100, Hungary  
Tel: 36 12204155  
Fax: 36 14221525

#### Ireland

##### Parker Hannifin Ireland Ltd.

Blackthorn Close,  
Stillorgan Industrial Park  
Blackrock, Co Dublin, Ireland  
Tel: 353 1 293 9999  
Fax 353 1 293 9900

#### Italy

**Parker Hannifin S.p.A.**  
Via Privata Archimede 1  
20094 Corsico (MI), Italy  
Tel: 39 02 451921  
Fax: 39 02 4479340

#### The Netherlands

**Parker Hannifin B.V.**  
Edisonstraat 1  
7575 AT Oldenzaal, The Netherlands  
Tel: 31 541 585000  
Fax: 31 541 585459

#### Norway

**Parker Hannifin A/S**  
Berghagan  
PO Box 3008  
N-1402 Ski, Norway  
Tel: 47 64 911000  
Fax: 47 64 911090

#### Poland

**Parker Hannifin Sp z o.o.**  
ul. Równolegla 8  
PL 02-435 Warsaw, Poland  
Tel: 48 22 573 24 00  
Fax: 48 22 573 24 03

#### Portugal

**Parker Hannifin Portugal, Lda.**  
Travessa da Bataria 184 R/C  
Dto./1 Esq.  
Leça da Palmeira-4450-625, Portugal  
Tel: 351 22 9997360  
Fax: 351 22 9961527

#### Romania

**Hidro Consulting Impex SRL  
Bucaresti Parker Representative  
Office**  
Bld. Ferdinand nr. 27 Sector 2  
RO-00001 Bucarest, Romania  
Tel: 0040 21 252 1382  
Fax: 0040 21 252 3381

#### Russia

**Parker Hannifin LLC**  
Rossolimo st., 17, floor 4  
119021 Moscow, Russia  
Tel: 7 095 580 91 45  
Fax: 7 095 580 91 45

#### Parker Hannifin LLC

**Branch Office Sakhalin**  
Zheleznodorozhnaya str., 174-A  
693008 Yuzhno-Sakhalinsk, Russia  
Tel: 7 4242 77 95 48  
Fax: 7 4242 77 27 42

#### Slovenia

**Parker Hannifin Corporation**  
Vel. Bucna vas 7  
SI-8000 Novo Mesto, Slovenia  
Tel: 386 7337 6650  
Fax: 386 7337 6651

(continued on next page)

## Parker Hydraulics International Sales Offices

### Europe

#### Spain

**Parker Hannifin España SA**  
Parque Industrial Las Monjas  
Calle Estaciones 8  
28850 Torrejón de Ardoz  
Madrid, Spain  
Tel: 34 91 6757300  
Fax: 34 91 6757711

#### Sweden

**Parker Hannifin AB**  
Fagerstagatan 51  
Box 8314  
SE-163 08 Spånga, Sweden  
Tel: 46 (0)8 59 79 5000  
Fax: 46 (0)8 59 79 5110

#### Turkey

**Parker Hannifin Corporation**  
Merter Is Merkezi  
Gen. Ali Riza Gurcan Cad. No: 2 / 67  
34067 Merter, Istanbul, Turkey  
Tel: 90 212 482 91 06  
Fax: 90 212 482 91 10

#### Ukraine

**Parker Hannifin Corporation**  
Vul. Velyka Vasylkivska 9/2 Office 59  
01004 Kiev, Ukraine  
Tel: 380 44 494 2731  
Fax: 380 44 494 2730

#### United Kingdom

**Parker Hannifin plc**  
Tachbrook Park Drive  
Tachbrook Park  
Warwick, CV34 6TU, England  
Tel: 44 1926 317878  
Fax: 44 1926 317855

### South Africa

**Parker Hannifin Africa Pty Ltd.**  
Parker Place  
10 Berne Avenue Aeroport  
P.O. Box 1153  
Kempton Park 1620,  
Republic of South Africa  
Tel: 27 11 9610700  
Fax: 27 11 3927213

### Middle East

#### Azerbaijan

**Parker Hannifin plc**  
**Azpar, Technical Representative**  
140 Alovst Guliyev St. Apt. 10  
370000 Baku, Azerbaijan  
Tel: 994 12 498 3966  
Fax: 994 12 498 3966

#### Kazakhstan

**Parker Hannifin**  
**Gateway Ventures CA LTD, Representative**  
7A Kabanbai Batira  
480100 Alamyty, Kazakhstan  
Tel: 7 3272 505 800  
Fax: 7 3272 505 801

#### United Arab Emirates

**Parker Hannifin Corporation**  
PO Box 46451  
Abu Dhabi, United Arab Emirates  
Tel: 971 2 6788587  
Fax: 971 2 6793812

### Asia Pacific

#### Asia Pacific Headquarters

**Parker Hannifin Hong Kong Ltd.**  
8/F, Kin Yip Plaza, 9 Cheung Yee Street  
Cheung Sha Wan, Kowloon  
Hong Kong  
Tel: 852 2428 8008  
Fax: 852 2480 4256

#### Australia Headquarters

**Parker Hannifin Pty Ltd.**  
9 Carrington Road  
Castle Hill, NSW 2154, Australia  
Tel: 612 9634 7777  
Fax: 612 9842 5111

#### China Headquarters

**Parker Hannifin Fluid Power Systems  
& Components (Shanghai) Co., Ltd.**  
280 Yunqiao Road,  
Jinqiao Export Processing Zone  
Shanghai 201206, China  
Tel: 86 21 5031 2525  
Fax: 86 21 5834 3714

#### Parker Hannifin Beijing Office

Suite B9-11, 21/F, Hanwei Plaza  
No. 7 Guanghua Road  
Chaoyang District  
Beijing, 100004, China  
Tel: 86 10 6561 0520  
Fax: 86 10 6561 0526

#### India

**Parker Hannifin India Pvt Ltd.**  
Plot No. EL-26, TTC Industrial Area  
Mahape, Navi Mumbai 400 709, India  
Tel: 0091 022 56137081/2/3/4  
Fax 0091 022 27686841, 27686618

#### Japan

**Parker Hannifin Japan Ltd.**  
4-2-1 Tsujido-Shinmachi,  
Fujisawa, Kanagawa, 251-0042, Japan  
Tel: 81 466 35 3050  
Fax: 81 466 35 2019

#### Korea Headquarters

**Parker Hannifin Korea Ltd.**  
Daehwa Venture Plaza, 6F  
169 Samsung-Dong  
Kangnam-ku, Seoul, 135-090, Korea  
Tel: 82 2 559 0400  
Fax: 82 2 556 8187

#### Singapore

**Parker Hannifin Singapore**  
No. 11, Fourth Chin Bee Road  
Jurong Town, Singapore, 619702  
Tel: 65 6887 6300  
Fax: 65 6265 5125

#### Taiwan

**Parker Hannifin Taiwan Co., Ltd.**  
No. 40, Wuchiuan 3rd Rd.,  
Wuku Industrial Park  
Taipei County, Taiwan 248, R.O.C.  
Tel: 886 2 2298 8987  
Fax: 886 2 2298 8982

#### Thailand

**Parker Hannifin Thailand Co., Ltd.**  
1023, 3rd floor, TPS building  
Pattanakarn Road, Suanluang  
Bangkok 10250, Thailand  
Tel: 662 717 8140  
Fax: 662 717 8148

### Latin America

#### Pan American Division

7400 NW 19th Street, Suite A  
Miami, FL 33126 USA  
Tel: 305-470-8800  
Fax: 305-470-8808

#### Argentina

**Parker Hannifin Argentina SAIC**  
Stephenson 2711 esq. Costa Rica  
1667 Tortuguitas  
Buenos Aires, Argentina  
Tel: 54 3327 44 4129  
Fax: 54 3327 44 4199

#### Brazil

**Hydraulics Division**  
**Parker Hannifin Ind. e Com. Ltda.**  
Av. FredericoRitter, 1100  
Cachoeirinha RS, 94930-000 Brazil  
Tel: 55 51 3470 9144  
Fax: 55 51 3470 9281

#### Chile

**Parker Hannifin Chile Ltd.a.**  
Av. Americo Vespucio 2760-E  
Conchali - Santiago, Chile  
Tel: 56-2-623-1216  
Fax: 56-2-623-1421

#### Venezuela

**Parker Hannifin de Venezuela, S.A.**  
Av. Principal con calle Miraima  
Edificio Draza  
Boleita Norte  
Caracas, Venezuela  
Tel: 58 212 238 5422  
Fax: 58 212 239 2272





# Extensive Hydraulic Product Offering

## Accumulators



Piston, bladder and diaphragm type accumulators, gas bottles and KleenVent reservoir isolators.

[www.parker.com/accumulator](http://www.parker.com/accumulator)

## Compact Hydraulics



Self-contained with a motor, gear pump, reservoir, internal valving, load hold checks and relief valves.

[www.parker.com/oildyne](http://www.parker.com/oildyne)

## Cylinders



Standard and custom hydraulic cylinders for industrial and mobile applications.

[www.parker.com/hydcyl](http://www.parker.com/hydcyl)

## Electronics/Remote Controls



Parker's unique IQAN approach combines sturdy, well-tested hardware with intelligent, flexible computing power.

[www.parker.com/iqan](http://www.parker.com/iqan)

## Filtration



Pressure and return line filters enhances machine life, reduces maintenance and lowers costs.

[www.parker.com/hydraulicfilter](http://www.parker.com/hydraulicfilter)

## Integrated Hydraulic Circuits

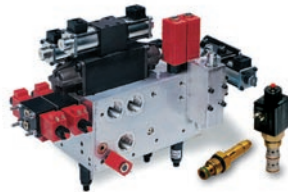

Solutions for complex circuits that include threaded cartridge valves integrated into a single manifold.

[www.parker.com/ihd](http://www.parker.com/ihd)

## Motors



Full line of high and low speed motors provides power up to 15,000 in-lbs of torque.

[www.parker.com/pumpmotor](http://www.parker.com/pumpmotor)

## Power Take Off



Parker Chelsea leads the industry for engineering, innovation and performance in auxiliary power systems.

[www.parker.com/chelsea](http://www.parker.com/chelsea)

## Power Units



The most complete line of standard, pre-engineered, cataloged hydraulic power units in the industry.

[www.parker.com/pumpmotor](http://www.parker.com/pumpmotor)

## Pumps



Broad line of energy-efficient hydraulic pumps that includes piston, vane and gear pumps.

[www.parker.com/mobpump](http://www.parker.com/mobpump)

## Rotary Actuator



Industry leader in the design and manufacture of hydraulic rack and pinion, and vane style rotary actuators.

[www.parker.com/actuator](http://www.parker.com/actuator)

## Valves and Controls



Hydraulic valves for virtually every hydraulic equipment application, from simple to precise control.

[www.parker.com/hydraulicvalve](http://www.parker.com/hydraulicvalve)

Covering the Industrial, Mobile and Truck markets, each catalog is paired with an interactive CD. Call for your comprehensive guides today. 1-800-CParker

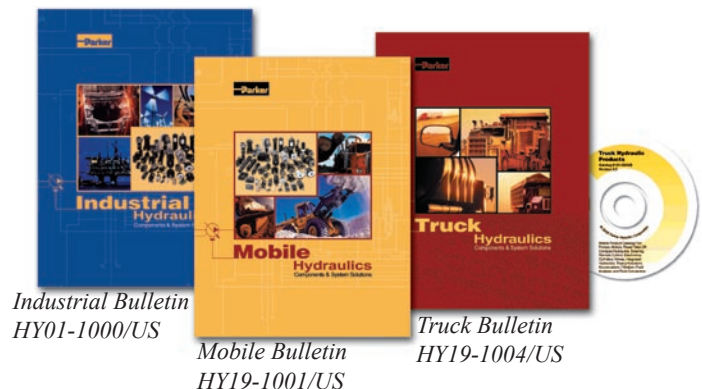

Industrial Bulletin  
HY01-1000/US

Mobile Bulletin  
HY19-1001/US

Truck Bulletin  
HY19-1004/US

**Parker Hannifin  
Hydraulic Valve Division**  
Elyria, Ohio USA

**Parker Hannifin  
Industria e Comercio Ltda**  
Cachoeirinha RS, Brazil

**Parker Hannifin  
Mobile Controls Division**  
Borås, Sweden

**Parker Hannifin  
Mobile Control Division Asia**  
SiHeung-City, Gyunggi-Do, Korea



**Parker Hannifin Corporation  
Hydraulic Valve Division**  
520 Ternes Avenue  
Elyria, Ohio 44035 USA  
Tel: (440) 366-5200  
Fax: (440) 366-5253

**Parker Hannifin  
Industria e Comercio Ltda**  
Av. Frederico Ritter, 1100  
Cachoeirinha RS, 94930-000 Brazil  
Tel: 55-51-3470-9144  
Fax: 55-51-3470-9281

**Parker Hannifin AB  
Mobile Controls Division**  
Almenäsvägen 22  
S-501 78 Borås, Sweden  
Tel: 46-33-7005200  
Fax: 46-33-121143

**Parker Hannifin  
Mobile Control Division Asia**  
1268-6, JeongWang-Dong,  
SiHeung-City, Gyunggi-Do  
Korea, 429-849  
Tel: 82-31-498-2761  
Fax: 82-31-498-2766



[www.parker.com](http://www.parker.com)

Catalog HY14-2720/US,  
5M, 3/06, PPI